



# CAMBRIA

*Cast Stone Mantles*



*For Wood & Gas Burning Fireplaces.*

# CAMBRIA CAST STONE MANTLE



**A** beautiful fireplace truly is the Heart of the Home. So furnishing the hearth with elements of quality and style is the foundation of the home's design character and quality.

*This is our passion at Hearthside Designs™; the exclusive provider of quality, handcrafted hearth furnishings for Desa Hearth Products.*

The new Cambria Precast Stone Mantle from Hearthside Designs is a classic French Renaissance design with Roman Arch and ornate keystone feature. It's formal presentation with bold yet fine details creates an ominous overall presence.

The Cambria is available in 4 sizes and 2 custom stone finishes which are integral to the stone material and factory sealed. The reinforced concrete construction is exceptionally durable with unsurpassed detail and quality. The Cambria is custom designed for easy installation on a variety of Fmi™, Vanguard® and Design Dynamics™ brand indoor and outdoor, gas and woodburning fireplaces\*. It features our patent-pending, fool proof installation system which self-centers the mantle and virtually eliminates field cutting, filling and touch up.

*\*See price catalogue for complete details.*

- Features:**
- Classic, European Styling
  - Reinforced Lightweight Concrete Construction
  - Factory Sealed, Integral Color Finish
  - Patent-Pending Mounting and Installation System
  - Limestone and Sandstone Finishes
  - Approved for use indoors and outdoors
  - All Mounting Hardware, Grout and Caulking Included

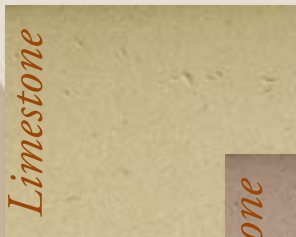

Limestone

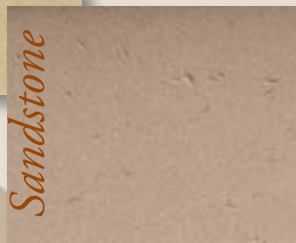

Sandstone



*The Cambria is a solid, single piece mantle and surround with face plate and hearth extension ordered separately.*

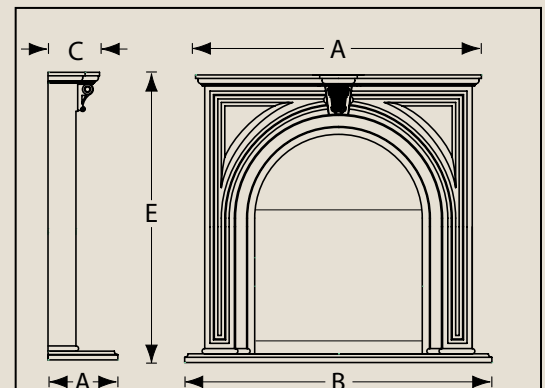

	36"	42"	48"	50"
A	76 1/2	76 1/2	82	82
B	88	88	88	88
C	12 1/8	12 1/8	10 3/4	10 3/4
D	20	20	20	20
E	71 3/4	71 3/4	82 1/4	82 1/4

