

RCBHC

VARIABLE FLAME REMOTE CONTROL INSTALLATION AND OPERATING INSTRUCTIONS FOR CONCENTRIC VARITAP, LATCHTAP AND MAXTROL VALVES

This remote control system provides a safe, reliable, and user-friendly remote control for Concentric Varitap, latchtap and maxitrol valve gas appliances. The system can be manually turned On/Off or can remotely control the flame adjustment. Always check with the home owner's manual of the appliance for additional information, or warnings regarding accessory installation before connecting this remote control system.

Carefully inspect the contents for shipping damage. If any parts are missing or damaged, immediately contact the dealer from whom you purchased the kit. Do not attempt to install any part of the kit unless all parts are in good condition. Please keep this booklet for future reference.

CONTENTS OF KIT

Description	Qty
Transmitter	1
Battery Alkaline AAA (for Transmitter)	3
Receiver (Assembly) consists of :	1
Receiver Box	
Battery Door Black	
Slide Button-Black (On/RS/Off)	1
Wall Cover Plate-Black	1
Battery Alkaline AA (for Receiver)	4
Velcro (Loop and Hook)	1
Plug-In Wiring Assembly – 22” Inches	1
Installation Instructions	1
#8 Screw for sheet metal, Black	2

FEATURES/SPECIFICATIONS

- Battery Powered Transmitter and Receiver
- Easy Access Front Battery Door
- Pre-Programmed for Quick Installation
- 16 Security Codes
- Optional 6 hour shutdown
- Quick Disconnect Wiring Assembly

WARNING Important Safety Information

- Read this manual thoroughly prior to installing, programming or operating this remote control system.
- This remote control system is designed for use with a Concentric varitap, latchtap and maxtrol gas valve system. Do not use this remote control system on appliances with other types of gas valve.

- This remote control system requires three (3) “AAA” and four (4) “AA” alkaline batteries to power the transmitter and receiver respectively. Wiring must conform to appliance requirement and building codes/ordinances as required by local and national code authorities having jurisdiction in your area.
- This remote control system should only be used as described in this manual and any other use is not recommended and will void the warranty.

WARNING

Turn appliance OFF and allow to cool before installing or servicing. DO NOT connect 110-120 VAC wiring to the gas control valve. The remote control system must be installed exactly as outlined in these instructions. Read all instructions completely before attempting installation and follow instructions carefully during installation. Any modification of components or failure to follow instructions exactly will void the warranty and may cause a fire hazard.

INSTALLATIONS

Remote Receiver:

The remote receiver may be wall mounted or installed in the appliance per the appliance homeowner’s manual. **Refer to the Homeowner’s Manual for special installation instructions.** Failure to follow the installation instructions found in the appropriate Homeowner’s Manual will void the warranty and may cause a fire hazard.

Installing Batteries:

The remote receiver uses four (4) “AA”- size batteries. To install batteries,

1. Open the battery door by pressing the two tabs located on the door.
2. Install the batteries as indicated on the receiver door.
3. Gently, close the battery door until the door tab snaps in place.
4. Install the receiver into the appliance, refer to the Homeowner’s Manual of appliance for installation instructions.
5. The batteries should be replaced at least once every 6 months or when the battery indicator light flashes, slowly and periodically red.

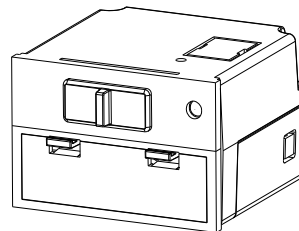

Installing Wire:

This system comes with an 22 inch pre-assembled wire assembly. Insert the four-pin black terminal wire into the back of the receiver. The terminal wire block can only be installed one way and do not force the terminal plug into the receiver.

Follow the homeowner’s manual for connecting the two (2) 1/4” female spade terminals to the gas valve. Make sure that the color of valve wires matches the color tag of the wiring from receiver, exception with the Concentric latchtap wires are reversed in color. Please refer to the following diagram for wiring directions.

If valve operates in reverse direction, simply reverse the wires and valve should operate correctly.

For applications longer than 22 inches, use 18 gauge wire, 105°C rated, with no splices by using the appropriate connectors. Connect to the two (2) 1/4” female spade wiring terminals and wire can be no longer than 20 feet.

WARNING

Make sure that the wires do not contact the appliances any place other than at the terminals. Exposure to temperatures higher than 105C (250°F) may cause the receiver to malfunction and/or cause a fire hazard.

If you connect wires wrong, the valve will operate in the wrong direction.

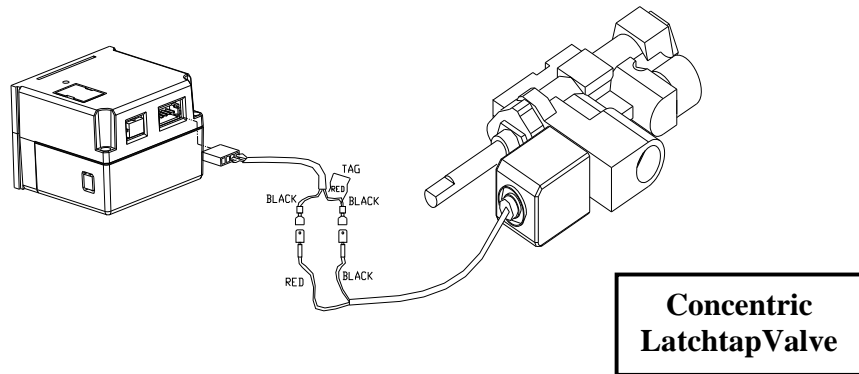
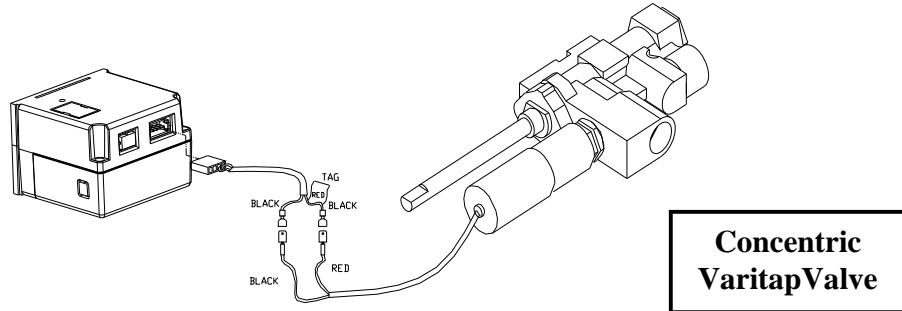

Note For Latchtap valve only. Wires are reversed in color. The tagged red wire must be connected to the black wire from the valve.

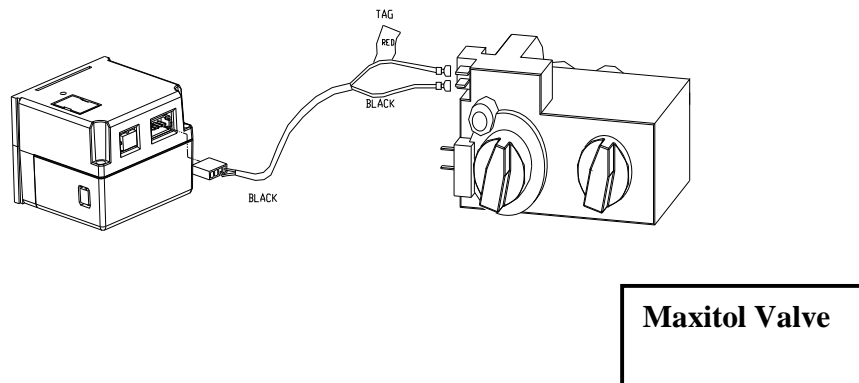

Remote Transmitter:

Installing Batteries:

The remote transmitter uses three (3) “AAA”- size batteries. To install batteries,

1. Press down the battery door tab and pull out to remove the battery door.
2. Install the batteries as indicated in the battery compartment.
3. Gently, close the battery door by snapping in place.
4. The batteries should be replaced at least once every 6 months or when the battery indicator is displayed on LCD screen.

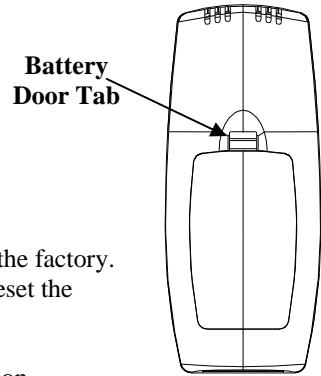

In code

Back of the Transmitter

Setting Privacy (DIP) Switch on Receiver and Transmitter:

The remote receiver and transmitter privacy (DIP) switches are preset at the factory. In the event of activation or interference from other nearby transmissions, reset the system using the following procedure:

1. Remove battery cover door from transmitter & pry up small rectangle on top of receiver to view DIP switches.
2. Slide the DIP switches on the transmitter and receiver to your choice of ON or OFF position. Switches #1, #2, #3 and #4 are preset to “ON” for both the transmitter and receiver.
3. The switches on the transmitter and receiver must match exactly in order for the system to work.
4. The system is now ready to operate.

Note See optional auto shutdown on page 5 of 7.

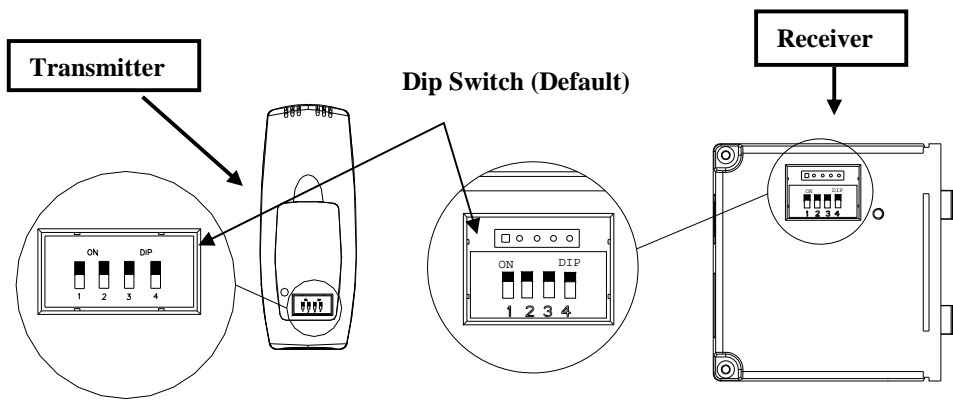

WARNING
Do not use two (2) or more remote control systems in the same area with the same dip switch settings, as they will communicate with each other and may cause the appliances to malfunction.

OPERATIONS:

Transmitter:

General:

The RCBHC is an On/Off and High/Low remote control.

The transmitter will operate the remote receiver from 1 foot to a maximum of 30 feet. The operational range is reduced when batteries are low or when the receiver is located inside a metal enclosure.

Initial start up:

Follow the homeowner installation instruction for the proper lighting of the pilot and appliance. After initial power up, the transmitter is ready for use.

IMPORTANT: Before igniting the pilot, press and hold the **ON/HI** button of transmitter to turn on the valve to its full high position. Once pilot is lit and appliance is turned on, adjust flame height to your desired position, see operation procedure below.

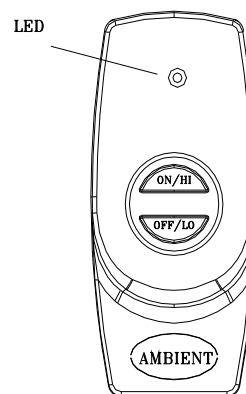

Operation Procedure:

1. Press and hold the **ON/HI** button to turn on the appliance to HI - full on position.
2. Press the **OFF/LO** button to decrease the flame height desired.
3. Press the **ON/HI** button to increase the flame height desired.
4. Continue to hold the **OFF/LO** button to completely turn off flame.

Low-battery detection:

When the battery voltage drops to a certain level, which is checked once a minute, the LED on the transmitter will blink until the batteries expire. Change the batteries before they are too weak for normal operation. **TURN THE UNIT OFF BEFORE REPLACING BATTERIES.**

Receiver:

Low-battery detection:

When the battery voltage drops to a certain level, which is checked once a minute, the low-battery LED will start to blink and the receiver **will automatically turn off the appliance**. The receiver will not function again until fresh batteries are installed.

Optional Auto Shutdown:

1. The receiver comes preset from the factory with a 6 hour shutdown from its last ON operation. This is done to prevent the appliance from continuing to run if unattended.
2. You may disable this feature if you wish. To disable, change the receiver privacy (DIP) switch #1 **ONLY** to the OFF position. Make sure the transmitter privacy (DIP) switches are set the same. Follow the instructions on Setting Privacy (DIP) Switch on Receiver & Transmitter discussed earlier in this manual.
3. **By disabling this feature, your appliance may continue to run unattended.**

Slide Switch:

1. ON position: the system will remain ON (Highest Setting) until the slide switch is placed in the OFF or RS position. When switching to RS position, the system will stay 100% on.
2. RS position: the system will only operate if the remote receiver receives a signal from the transmitter. OFF position, the system is completely off. The slide switch should be placed in the OFF position if you will be away for an extended period of time. If the remote receiver is mounted out of children's reach, the OFF position also functions as a safety device by both turning the system off and rendering the receiver inoperable.

WARNING: IT IS RECOMMENDED TO TURN THE RECEIVER SLIDE SWITCH TO THE OFF POSITION WHEN YOU INTEND TO BE AWAY FOR AN EXTENDED PERIOD OF TIME

TESTING YOUR NEW REMOTE CONTROL SYSTEM

Refer to the appropriate Homeowner's Manual for proper wiring connections to the appliance and connect the wiring terminals to the appliance as instructed.

1. Light your gas appliance following the appliance lighting instructions that comes with the appliance. Confirm that the pilot light is on and valve is in the on position; it must be in on position for the remote control to operate the main gas valve.
2. Slide the 3 position button on the remote receiver to the ON position. The main gas flame should ignite and it will take a few seconds for valve to reach 100% on – highest flame position.
3. Slide the button to OFF. The flame should decrease and extinguish a few second later (the pilot light will remain on).
4. Slide the button to RS (the center position), then press and hold the **ON/HI** button on the transmitter to turn the system to full ON. The main gas flame should ignite.
5. Press the **OFF/LO** button on the transmitter to decrease flame height. Continue to press and hold the **OFF/LO** button to completely turn system to OFF. The flame should extinguish (the pilot light will remain on).

TROUBLESHOOTING

Symptom	Causes	Action
1. LED light on transmitter / receiver blinking	1. Low Battery	1. Replace batteries. Change batteries every 6 months.
2. Appliance does not come on after pressing the ON/HI on transmitter	1. Wiring / Electrical Connections	1. Slide the switch to ON, if appliance comes 100% ON gradually, wiring is not the causes. 2. If appliance does not come on, check wiring connections.
	2. Privacy (DIP) switch setting on transmitter does not match receiver	1. Make sure the transmitter and receiver have the same DIP switch settings.
	3. Distance between the transmitter and receiver is more than 30 feet	1. Make sure the operating distance is less than 30 feet
3. Receiver cannot receive signal.	1. Receiver is installed in an enclosure	1. Make sure the receiver is not located inside to tight of an

		enclosure.
4. Flame goes down/up when pressing the ON/HI and up when pressing the OFF/LO on transmitter	1. Wiring is backward	1. Switch the two wires on the back of receiver.

WARNING

Changes or modifications to this unit not expressly approved by the party responsible for compliance could void the user's authority to operate the equipment.

NOTE

This equipment has been tested and found to comply with the limits for a Class B digital device, pursuant to Part 15 of the FCC Rules. These limits are designed to provide reasonable protection against harmful interference in a residential installation. This equipment generates uses and can radiate radio frequency energy and, if not installed and used in accordance with instructions, may cause harmful interference to radio communications. However, there is no guarantee that interference will not occur in a particular installation. If this equipment does cause harmful interference to radio or television reception, which can be determined by turning the equipment off and on, the user is encouraged to try to correct the interference by one or more of the following measures:

- Reorient or relocate the receiving antenna.
- Increase the separation between the equipment and receiver.
- Connect the equipment into an outlet on a circuit different from that to which the receiver is connected.
- Consult the dealer or an experienced radio/TV technician for help.

WARRANTY

This warranty gives you specific legal rights and you may also have other rights that vary from state to state or province to province. Answers to any questions regarding our limited warranty may be obtained by writing to our corporate offices.

Ambient Technologies warrants each new Ambient Technologies remote control against any defects that are due to faulty material or workmanship to the original owner, for a period of five years from the original date of purchase. This warranty and our liability does not apply to batteries, nor does it include damage to merchandise or the remote control resulting from accident, alteration, neglect, misuse, improper installation or any other failure to follow Ambient Technologies installation and operating instructions.

After contacting Ambient Technologies Tech Service to receive a return authorization number, we agree to repair or replace at our option any Ambient Technologies remote control under warranty. Provided it is returned postage prepaid to our warranty facility in a padded carton within the warranty period, with proof of the original date of purchase and a brief description of the malfunction. This limited warranty does not include the cost of removal or re-installation.

Ambient Technologies
149 Cleveland Drive
Paris KY 40361

**FOR TECHNICAL SUPPORT
CALL 800-398-6195**