

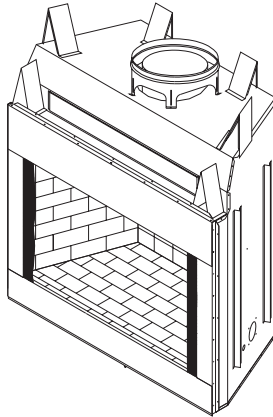

RESIDENTIAL AND OUTDOOR WOODBURNING FIREPLACE OWNER'S OPERATION AND INSTALLATION MANUAL



(V)JM36, (V)JM42 AND (V)JM50 WOOD BURNING MASONRY FIREPLACES WITH INSULATION

SAVE THIS BOOK

This book is valuable. In addition to instructing you on how to install and maintain your appliance, it also contains information that will enable you to obtain replacement parts or accessory items when needed. Keep it with your other important papers.

This fireplace is approved for use as a wood burning fireplace or for use with a vented gas log approved to ANS Z21.60, Z21.84 or RGA 2-72 standards or for use with a vent-free gas log heater approved to ANS Z21.11.2 standard.

This wood burning fireplace complies with UL127-CAN/ULS-S610-M87 standard as a **FACTORY BUILT APPLIANCE**.

FOR CANADA: The authority having jurisdiction (such as the municipal building department, fire department, etc.) should be contacted before installation to determine the need to obtain a permit.

WARNING: Improper installation, adjustment, alteration, service or maintenance can cause injury, property damage or loss of life. Refer to this manual for assistance or additional information. Consult a qualified installer or local distributor.

TABLE OF CONTENTS

Safety Information	2	Brick Installation	13
Specifications	3	Glass Door Installation	20
Fireplace Installation.....	6	Operation and Maintenance Guidelines	21
Venting Installation	8	Technical Service.....	23
Optional Gas Line Installation.....	12	Replacement and Accessory Parts.....	23

SAFETY INFORMATION

IMPORTANT: Check local codes before installing this fireplace.

Before beginning the installation of the fireplace, read these instructions through completely.

- This DESA fireplace and its components are safe when installed according to this installation manual. Unless you use DESA components, which have been designed and tested for the fireplace system, you may cause a fire hazard.
- The DESA warranty will be voided by and DESA disclaims any responsibility for the following actions.
 - a. Modification of the fireplace, components, doors, air inlet system and damper control.
 - b. Use of any component part not manufactured or approved by DESA in combination with a DESA fireplace system.

Proper installation is the most important step in ensuring safe and continuous operation of the fireplace. Consult the local building codes as to the particular requirements concerned with the installation of all factory built fireplaces.

⚠ WARNING: Do not install a fireplace insert in this box unless the manufacturer's instructions with the insert specifically state this fireplace has been tested for use with this insert.

FOR YOUR SAFETY

- **Do not store or use gasoline or any other flammable vapors or liquids in the vicinity of this or any other appliance.**
- **Due to high temperatures, the appliance should be located out of traffic and away from furniture and draperies.**
- **Do not place clothing or other flammable materials on or near the appliance.**
- **Never leave children unattended when a fire is burning in the fireplace.**

⚠ WARNING: Use solid wood or processed solid fuel firelogs only. When processed wood fuel fire logs are used, do not poke or stir the logs while they are burning. Use only fire logs that have been evaluated for the application in fireplace and refer to fire log warnings and caution markings on packaging prior to use.

This fireplace is not intended to be used as a substitute for a furnace to heat an entire home. Use for supplemental heat only.

SPECIFICATIONS

MODELS VJM36 AND JM36

ROUND TOP TERMINATION

SQUARE CHASE-TOP
TERMINATION

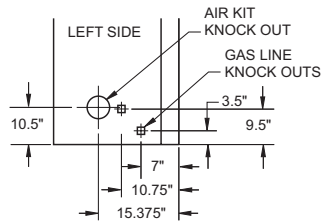
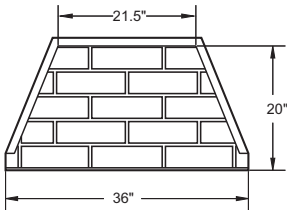
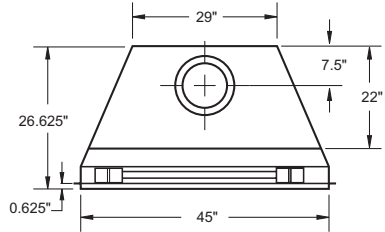
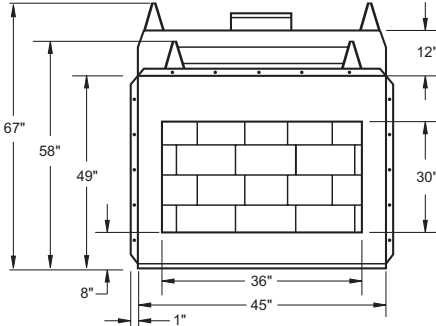
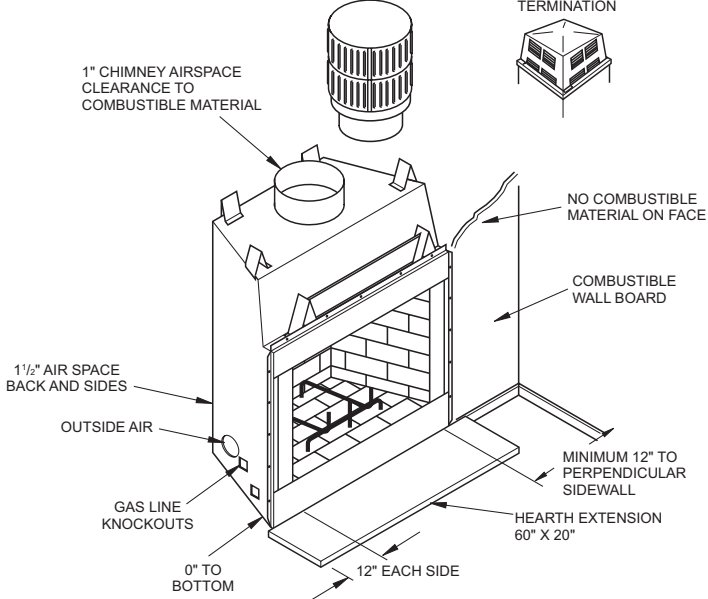

SPECIFICATIONS *Continued*

MODELS VJM42 AND JM42

ROUND TOP TERMINATION

SQUARE CHASE-TOP
TERMINATION

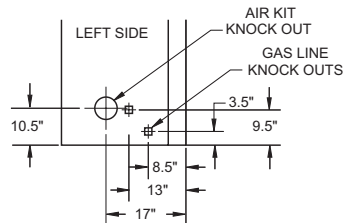
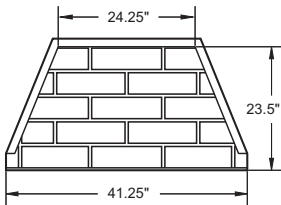
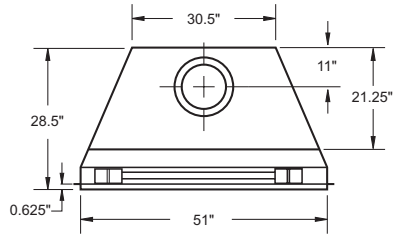
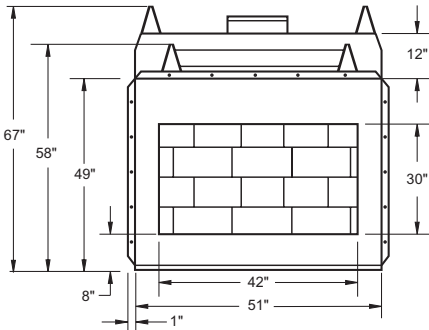
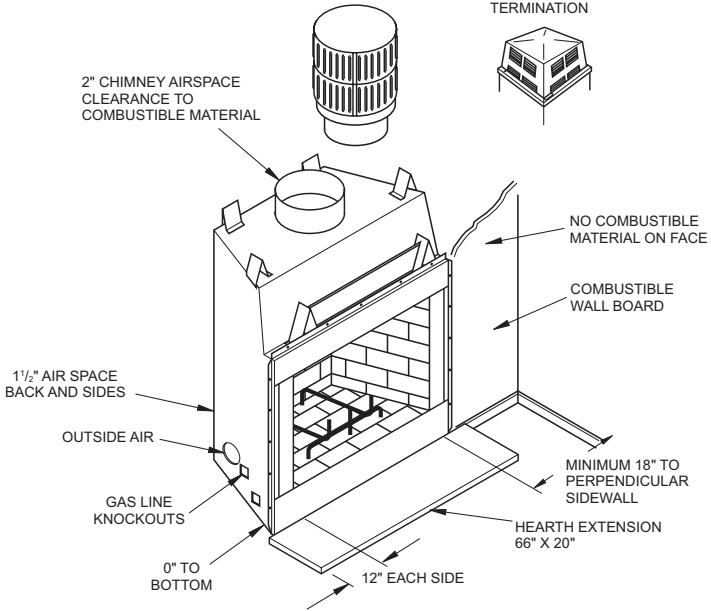

SPECIFICATIONS *Continued*

MODELS VJM50 AND JM50

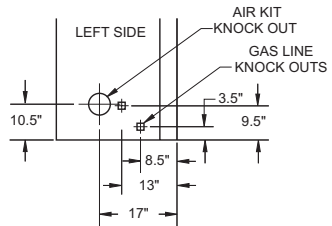
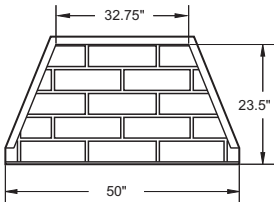
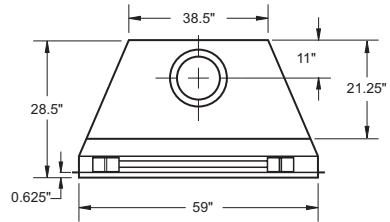
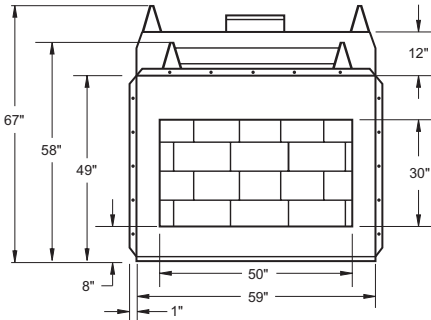
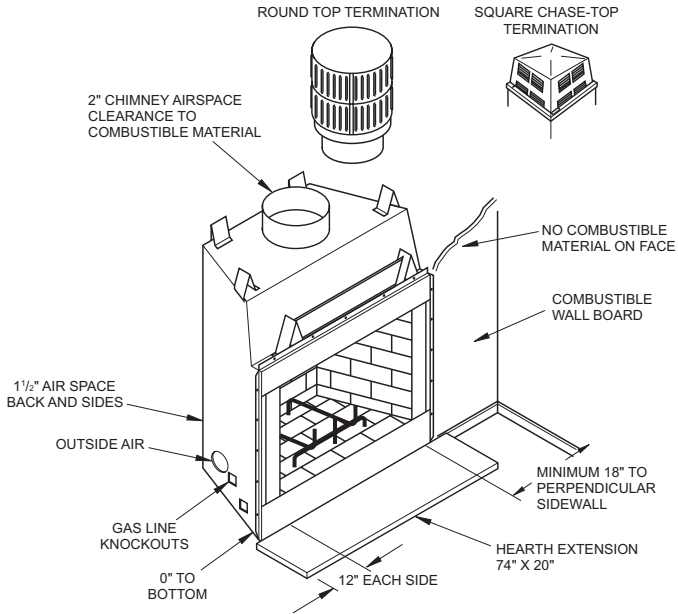

FIREPLACE INSTALLATION

SELECTING LOCATION

To determine the safest and most efficient location for the fireplace, you must take into consideration the following guidelines:

1. The location must allow for proper clearances (see Figures 1 and 2).
2. Consider a location where the fireplace will not be affected by drafts, air conditioning ducts, windows or doors.
3. A location that avoids the cutting of joists or roof rafters will make installation easier.
4. An outside air kit is available with this fireplace (see *Optional Outside Air Kit* on page 8).

MINIMUM CLEARANCE TO COMBUSTIBLES

Back and sides of fireplace	1 1/2" min.*
Front of fireplace	48" min.
Floor**	0" min.
Perpendicular wall to opening	18" min.
Model JM36	12" min.
Top spacers	0" min.
Mantel clearances	see <i>Mantels</i> , page 7
Chimney outer pipe surface	2" min.
Model JM36	1" min.

* Not required at nailing flanges

** See step 2 of *Framing*

WARNING: Do not pack required air spaces with insulation or other materials.

Minimum/Maximum Chimney Height for Residential Installation

The minimum height of the chimney, measured from the base of the fireplace to the flue gas outlet of the termination, is 16 feet for straight flue or a flue with one elbow set. The maximum distance between elbows is 6 feet. For systems with two elbow sets, the minimum height is 22 feet. The maximum height of any system is 50 feet. This measurement includes the fireplace, chimney sections and the height of the termination assembly at the level of the flue gas outlet (see Figure 15, page 11).

Minimum/Maximum Chimney Height for Outdoor Installation

The minimum height of the chimney, measured from the base of the fireplace to the flue gas outlet of the termination, is 9.5 feet (minimum of 4 feet of chimney pipe sections required for outdoor installation).

FRAMING

1. Frame the opening for the fireplace using the dimensions shown in Figures 1 and 2.
2. If the fireplace is to be installed directly on carpeting, tile (other than ceramic) or any combustible material other than wood flooring, the fireplace must be installed upon a metal or wood panel extending the full width and depth of the fireplace.
3. Set the fireplace directly in front of this opening and slide the unit back until the nailing flanges touch the side framing.
4. Check the level of the fireplace and shim with sheet metal if necessary.
5. Before securing fireplace to prepared framing, the ember protector (provided) must be placed between the hearth extension (not supplied) and under the bottom front edge of the fireplace to protect against glowing embers falling through. If the fireplace is to be installed on a raised platform, a Z-type ember protector (not supplied) must be fabricated to fit your required platform height. The ember protector should extend under the fireplace a minimum of 1 1/2". The ember protector should be made of galvanized sheet metal (28 gauge minimum to prevent corrosion).
6. Using screws or nails, secure the fireplace to the framing through flanges located on the sides of the fireplace.

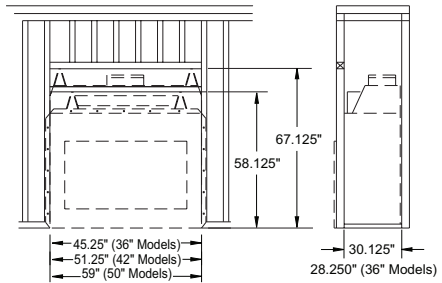

Figure 1 - Framing Dimensions

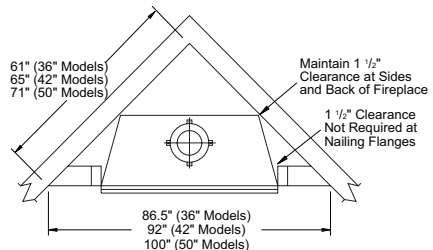

Figure 2 - Corner Installation

FIREPLACE INSTALLATION

Continued

Note: For outdoor installations, the fireplace enclosure must allow for adequate drainage and fresh air ventilation. It is recommended that a sealed, corrosion resistant catch pan with provision for drainage be installed under the fireplace within the fireplace enclosure.

HEARTH EXTENSION

A hearth extension projecting a minimum of 20" in front of and a minimum of 12" beyond each side of the fireplace opening is required to protect combustible floor construction in front of the fireplace. Fabricate a hearth extension using a material which meets the following specifications: a layer of noncombustible, inorganic material having a thermal conductivity of $K=0.84$ BTU IN/FT, HR, F (or less) at 1" thick. For example, if the material selected has a K factor of 0.25, such as glass fiber, the following formula would apply:

$$\frac{0.25}{0.84} \times 1.0" = 0.30" \text{ thickness required}$$

Thermal conductivity "K" of materials can be obtained from the manufacturer or supplier of the noncombustible material. If the hearth extension is to be covered, use noncombustible material such as tile, slate, brick, concrete, metal, glass, marble, stone, etc. Provide a means to prevent the hearth extension from shifting and seal gap between the fireplace frame and hearth extension with a non-combustible material (see Figure 3).

WARNING: Hearth extension is to be installed only as shown in Figure 3.

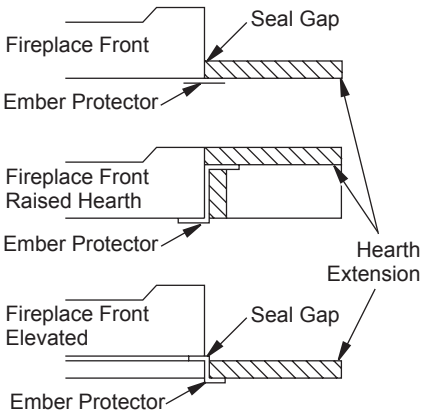

Figure 3 - Hearth Extension

MANTELS

A mantel may be installed if desired (see Figure 4). Woodwork such as wood trims, mantels or any other combustible material projecting from the front face must not be placed within 12" (JM36) or 18" (JM42/50) of the fireplace opening. Combustible materials above 12" (JM36) or 18" (JM42/50) and projecting more than 1 1/2" from the fireplace must not be placed less than 15" (JM36) or 21" (JM42/50) from the top opening of the fireplace (NFPA STD 211, Sec. 7-3.3.3).

Mantels or any other combustible material also may come up to the side edge of the black metal face of the fireplace just as long as the projection from the front face fall within the limit shown in Figure 4.

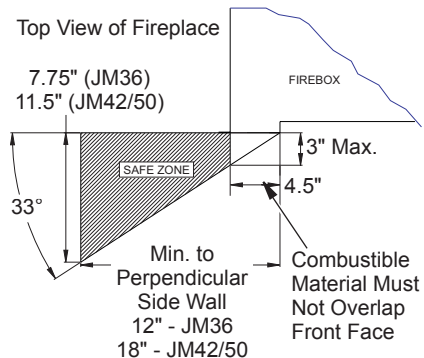
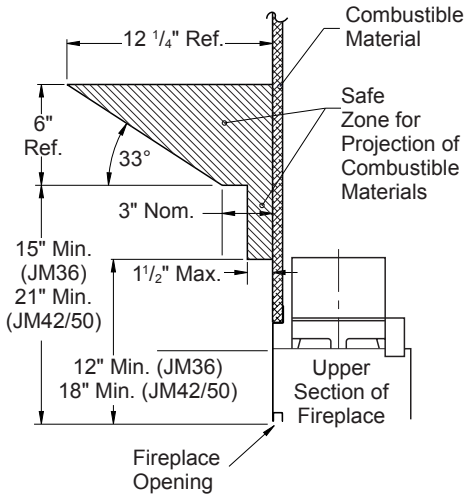

Figure 4 - Mantel Clearances to Combustible Material

VENTING INSTALLATION

OPTIONAL OUTSIDE AIR KIT (MODEL AK4/AK4F)

The installation of an outside air kit should be performed during the rough framing of the fireplace due to the nature of its location. Outside combustion air is accessed through a vented crawl space (AK4F) or through a sidewall (AK4).

CAUTION: Combustion air inlet ducts shall not terminate in attic space.

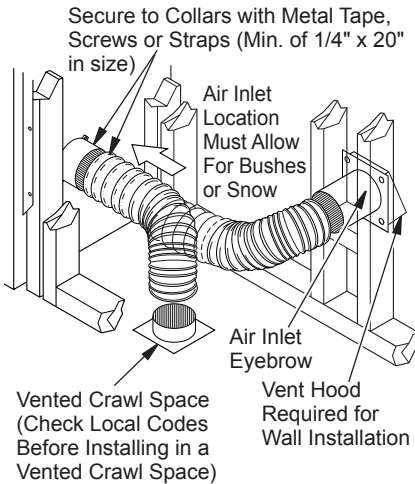

Figure 5 - Outside Air Kit

CHIMNEY PIPE

The DESA chimney system consists of 12", 18", 24", 36" and 48" snap-lock, double-wall pipe segments, planned for maximum adaptability to individual site requirements. Actual lengths gained after fitting overlaps must be taken into consideration (lineal gain) and are given in the lineal gain chart (see Figure 6). Lineal Gain is the actual measurable length of a part after two or more parts are connected. For Canada, use chimney parts designated "HT".

WARNING: The opening in the collar around the chimney at the top of the fireplace must not be obstructed. Never use blown insulation to fill the chimney enclosure.

LINEAL GAIN		
PART NO.	DESCRIPTION	GAIN
Georgian	Fireplace	66 1/2"
12-12DM	Pipe Section	10 5/8"
12-12HT		
18-12DM	Pipe Section	16 5/8"
18-12HT		
24-12DM	Pipe Section	23 5/8"
24-12HT		
36-12DM	Pipe Section	34 5/8"
36-12HT		
48-12DM	Pipe Section	46 5/8"
48-12HT		
RLT-12D	Round Termination	7 3/4"*
RLT-12HT		
STL-12D	Square Chase-Top with Slip Section	7" to 15"*

* The lineal gain for the terminations is measured to the flue gas outlet height.

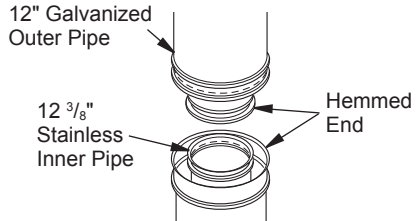

Figure 6 - Lineal Gain

ASSEMBLY AND INSTALLATION OF DOUBLE WALL CHIMNEY SYSTEM

Each double wall chimney section consists of a galvanized outer pipe, a stainless steel inner flue pipe and a wire spacer. The pipe sections must be assembled independently as the chimney is installed. When connecting chimney directly to the fireplace, the inner flue pipe section must be installed first with the lanced side up. The outer pipe section can then be installed over 5 the flue pipe section with the hemmed end up. Press down on each pipe section until the lances securely engage the hem on the fireplace starter. The wire will assure the proper spacing between the inner and outer pipe sections.

Continue to assemble chimney sections as outlined above, making sure that both the inner and outer pipe sections are locked together. When installing double wall snap-lock chimney together, it is important to assure the joint between the chimney sections is locked. Check by pulling chimney upward after locking. The chimney will not come apart if properly locked. It is not necessary to add screws to keep the chimney together (exception, see Figure 9, page 10).

VENTING INSTALLATION

Continued

USING ELBOW OFFSETS (30E-12DM)

1. To achieve desired offset, you may install combinations of 12", 18", 24", 36" and 48" length of double wall pipe (see offset chart and Figure 7).

OFFSET A	RISE B	CHIMNEY LENGTH				
		12"	18"	24"	36"	48"
4 3/8"	16 3/8"	ELBOW SET ONLY				
9 3/4"	25 1/2"	1				
12 3/4"	30 3/4"		1			
15"	34 3/4"			1		
18"	40"	1	1			
21 1/4"	46 1/4"				1	
23 3/4"	49 1/4"		1	1		
27 3/4"	56 3/4"					1
30"	60 3/4"		1		1	
33"	66"					1
36"	71"		1			1
38 1/4"	75"					2
41 1/4"	80 1/4"	1	1		1	
45"	86 3/4"				2	
46 3/4"	89 1/2"	1	1			1
51"	97"				1	1
53 1/4"	101"				2	
56 1/4"	106 1/4"					2
59 1/4"	111 1/2"		1		1	1
61 3/4"	115 1/2"	1				2
64 3/4"	120 3/4"		1			2
68 1/4"	127"				2	1
70"	130"	1	1			2
74 1/4"	137 1/2"	1			2	1
76 3/4"	141 1/2"		1		2	1
79 3/4"	146 3/4"				4	

OFFSET CHART (22-50 FT. SYSTEM HEIGHT)

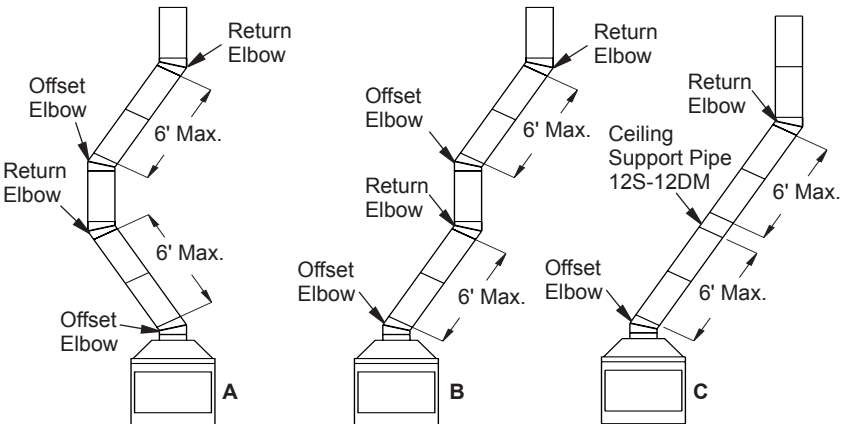

Figure 7 - Typical Offset Terminations

2. Chimney weight above offset rests on return elbow. Straps must be securely nailed to rafters or joists (see Figure 8, details a and b).
3. Maximum length of pipe between supports (return elbow or 12S-12DM) is 6' of angle run. Maximum of two 6' angle run sections per chimney system (see Figure 7).
4. All pipe connections between the offset and return must be secured with two screws on the outer pipe only (see Figure 9, page 10). Do not penetrate the inner stainless.

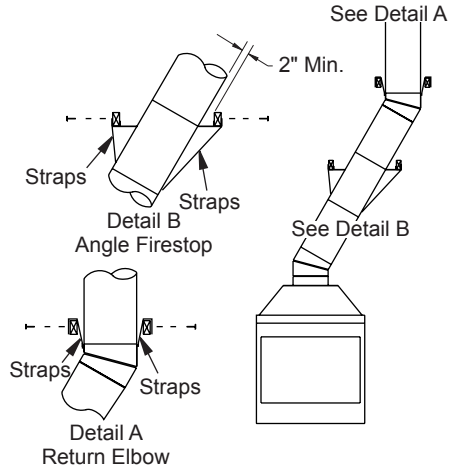

Figure 8 - Ceiling Support Pipe 12S-12DM

VENTING INSTALLATION

Continued

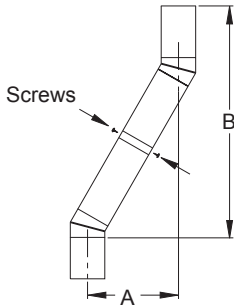

Figure 9 - Elbow Offset

FIRESTOP SPACERS (FS-10, 1100EFS-10DM FOR JM36)

Firestop spacers are required at each point where the chimney penetrates a floor space. Their purpose is to establish and maintain the required clearance between the chimney and the combustible materials. When the pipe passes through a framed opening into a living space above, the firestop must be placed onto the ceiling from below as shown in Figure 10.

They also provide complete separation from one floor space to another or attic space as required by most codes. When the double wall pipe passes through a framed opening into an attic space, the firestop must be placed into an attic floor as shown in Figure 11.

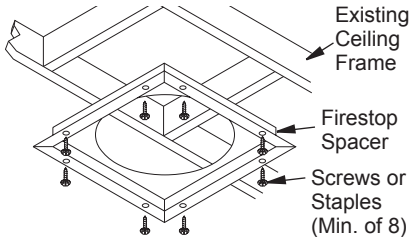

Figure 10 - Firestop Spacer with Living Space Above Ceiling

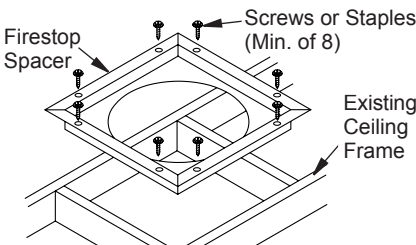
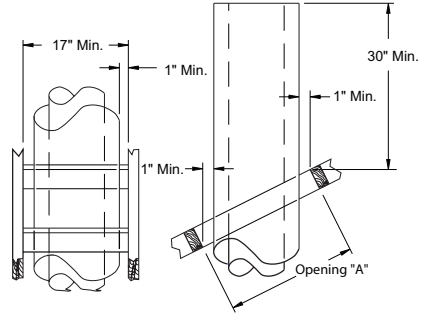

Figure 11 - Firestop Spacer with Attic Space Above Ceiling

PENETRATING THE ROOF

To maintain a 1" (JM36) or 2" (JM42/JM50) clearance to the pipe on a roof with a pitch, a rectangular opening must be cut.

1. Determine the center point through which the pipe will penetrate the roof.
2. Determine the center point of the roof. Pitch is the distance the roof drops over a given span, usually 12". A 6/12 pitch means that the roof drops 6" for each 12" one measure horizontally down from the roof rafters.
3. Use the roof opening chart (Figure 12) to determine the correct opening length and flashing required.



Pitch	Slope	Opening "A" Max.	Used Flashing Model No.
Flat	0°	17"	V6F-10DM
0-6/12	26.6°	19"	V6F-10DM
6/12-12/12	45.0°	24"	V12F-10DM

Roof Opening JM36

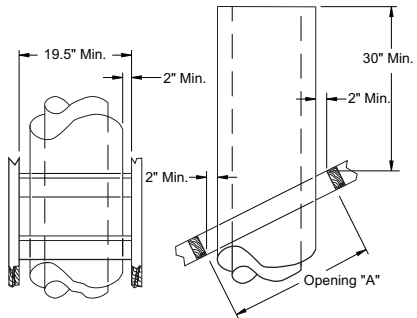

Pitch	Slope	Opening "A" Max.	Used Flashing Model No.
Flat	0°	19.5"	V6F-10DM
0-6/12	26.6°	22"	V6F-10DM
6/12-12/12	45.0°	27"	V12F-10DM

Roof Opening JM42/50

Figure 12 - Roof Opening Measurements

VENTING INSTALLATION

Continued

4. Remove the shingles around the opening measured. Cut out this section.
5. Add the next sections of the pipe until the end penetrates the roof line. Check to see that the proper clearances are maintained. Extend chimney by adding sections of double wall pipe until pipe is minimum of 30" above the highest point of the roof cutout. Termination and chimney must extend a minimum of 36" above the highest point where it passes through the roof.

FLASHING INSTALLATION (V6F-10DM OR V12F-10DM)

Determine the flashing to be used with the roof opening chart. Slide flashing over pipe until base is flat against roof. Replace as many shingles as needed to cover exposed area and flashing base. Secure in position by nailing through shingles (see Figure 13). **DO NOT NAIL THROUGH FLASHING CONE.**

Installing Flashing on a Metal Roof

When installing the flashing on a metal roof, it is required that putty tape be used between the flashing and the roof. The flashing must be secured to the roof using #8 x 3/4" screws and then sealed with roof coating to prevent leakage through the screw holes. A roof coating must also be applied around the perimeter of the flashing to provide a proper seal.

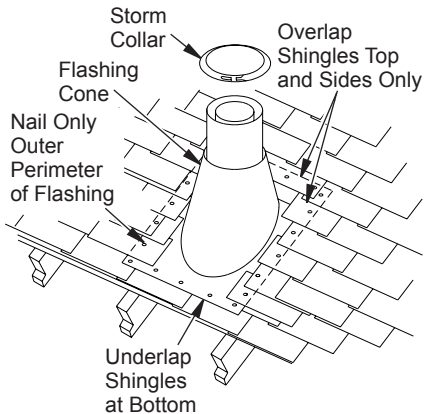

Figure 13 - Flashing Installation

Storm Collar Installation (SC2-1)

Place storm collar over pipe and slide down until it is snug against the open edge of the flashing (see Figure 14). Apply waterproof caulk around the perimeter of the collar to provide a proper seal.

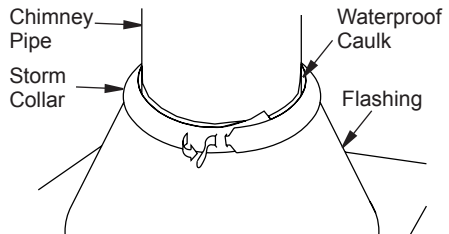

Figure 14 - Storm Collar

Terminations/Spark Arrestor

The fireplace system must be terminated with the listed round top or chase terminations. In any case, refer to the installation instructions supplied with the termination.

CAUTION: Do not seal openings on the rooftop flashing. Follow the installation instructions provided with the termination being used.

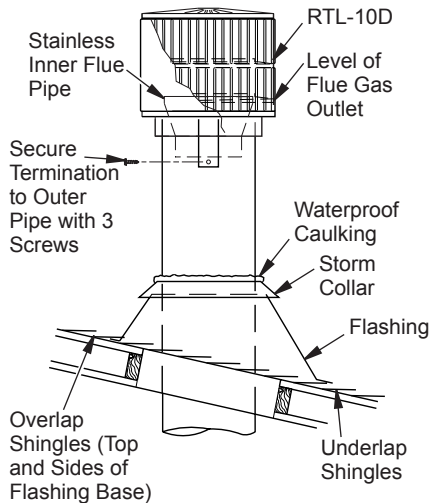

Figure 15 - Termination

VENTING INSTALLATION

Continued

CHASE INSTALLATIONS

Instructions for chase installations are included with the chase style termination chosen. In a multiple chase installation, be sure to provide adequate distance between terminations to prevent smoke spillage from one termination to another. We suggest that terminations be separated at least 24", center to center and stacked at a vertical height difference of 18" (see Figure 16).

Note: If a decorative shroud is to be installed, contact the manufacturer for specifications.

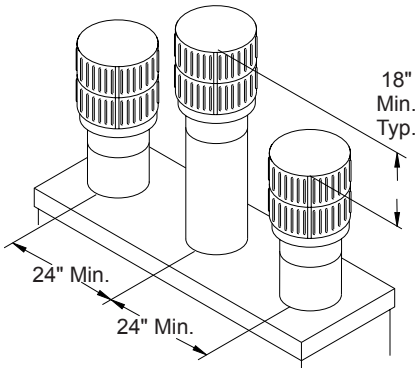

Figure 16 - Multiple Chase Installation

10 FOOT RULE

All flue gas outlet chimney terminations must extend a minimum of 3 feet in height above the highest point where it passes through the roof and must be at least 2 feet above the highest point of the roof that is within a horizontal distance of 10 feet (see Figure 17).

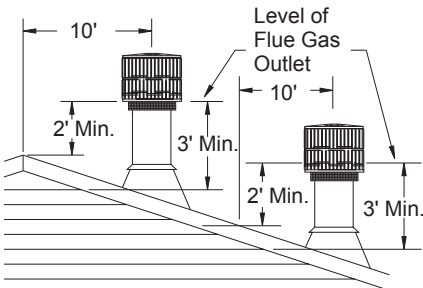

Figure 17 - 10 Foot Rule

FINISHING THE FIREPLACE

Combustible materials, such as wallboard, gypsum board, sheet rock, drywall, plywood, etc. may make direct contact with sides and top around the fireplace face. It is important that combustible materials do not overlap the face itself. Brick, glass, tile or other noncombustible materials may overlap the front face provided they do not obstruct essential openings like louvered slots or any other opening. When overlapping with a noncombustible facing material, use only noncombustible mortar or adhesive.

OPTIONAL GAS LINE INSTALLATION

Gas line hook up should be done by your supplier or a qualified service person.

Note: Before you proceed, make sure your gas supply is turned off.

Use only a 1/2" black iron pipe and appropriate fittings.

1. Remove knockout indentation on refractory or firebrick wall located above the refractory hearth floor. The knockout indentation must be firmly tapped with any solid object such as a 1/2" dowel until it is released. Remove fragmented portions of refractory (see Figure 18, page 13).
2. Remove gas line cover plate located on either side of fireplace and pull out insulation from gas line conduit sleeve. Replace screws.
3. Run a 1/2" black iron gas line into the fireplace through the rear at gas line conduit sleeve (if using a raised platform, add height). Provide sufficient gas line into fireplace chamber for fitting connection (see Figure 19, page 13).
Note: Secure incoming gas line to wood framing to provide rigidity for threaded end.
4. Repack insulation around gas line and into sleeve opening. Seal any gaps between gas line and refractory knockout hole with refractory cement or commercial furnace cement. Install the gas appliance or cap-off gas line if desired.

OPTIONAL GAS LINE INSTALLATION

Continued

CAUTION: All gas piping and connections must be tested for leaks after the installation is completed. After ensuring that the gas valve is on, apply soap and water solution to all connections and joints. Bubbles forming show a leak. Correct all leaks at once. **DO NOT USE AN OPEN FLAME FOR LEAK TESTING AND DO NOT OPERATE ANY APPLIANCE IF A LEAK IS DETECTED. LEAK TESTING SHOULD BE DONE BY A QUALIFIED SERVICE PERSON.**

WARNING: Do not operate an unvented gas log set in this fireplace with the chimney removed.

If you install a decorative gas appliance (vented gas log), the decorative gas appliance must comply with the *Standard for Decorative Gas Appliance for Installation in Solid Fuel Burning Fireplaces*, ANS Z21.60, Z21.84 or RG 2-72 and shall also be installed in accordance with the *National Fuel Gas Code*, ANSI 7223NFPA 54 latest edition.

WARNING: If the fireplace has been used for wood burning, the firebox and chimney must be cleaned of soot, creosote and ashes by a qualified chimney cleaner. Creosote will ignite if heavily heated.

WARNING: When using a decorative vented gas log, the damper must be removed or permanently locked in the fully open position and the glass doors must be in the fully open position.

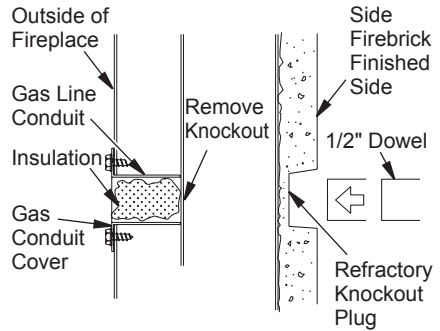

Figure 18 - Gas Line Knockout

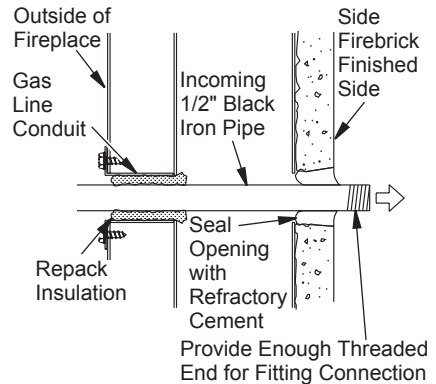

Figure 19 - Gas Line Installation

BRICK INSTALLATION

Installation of brick should be done after the fireplace is placed in a permanent location.

The brick housing panels are already installed in the firebox. Each housing is stamped with a letter (full size bricks are not stamped). These letters will help identify the brick when installing. It is important to install these bricks exactly as instructed. Press the brick firmly into the brick housing until it snaps. The groove line on the side of the brick will come in contact with the flange on the brick housing. This secures the brick into the housing. See Figure 20 on page 14.

The bricks are packaged in four separate boxes. These boxes are labeled by sections of the firebox.

Box #1 - Hearth Panel

Box #2 - Rear Panel

Box #3 - Left or Right Panel

Box #4 - Left or Right Panel

BRICK INSTALLATION

Continued

Install the bricks one section at a time starting with the hearth panel followed by the rear panel and then the left or right panel. It is important to install the bricks in sequence. **Note:** The left and right panels have identical bricks. Please note, full size bricks are NOT stamped.

Use brick "AO" (JM42 and JM50 only) or "AR" (JM36 only) if an optional gas line is installed. Mount brick "AO" or "AR" as shown in Figure 20. It is important that the knockout hole is in its proper location. The knockout hole on brick "AO" or "AR" should align with the hole on the brick housing.

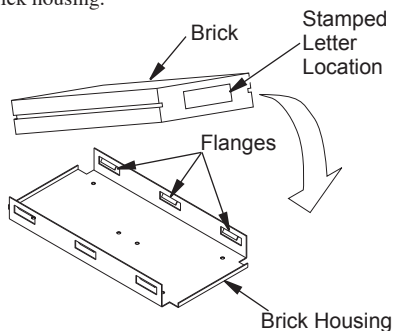

Figure 20 - Installing Brick

INSTALLING BRICK "AO" OR "AR"

Use brick "AO" (JM42 and JM50 only) or "AR" (JM36 only) if an optional gas line is installed. Mount brick "AO" or "AR" as shown in Figure 21. It is important that the knockout hole is in its proper location. The knockout hole on brick "AO" or "AR" should align with the hole on the brick housing.

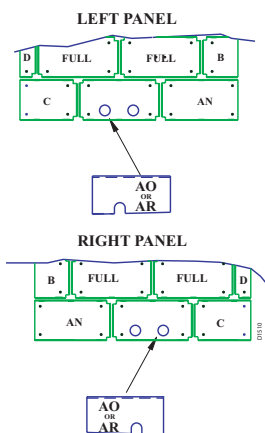
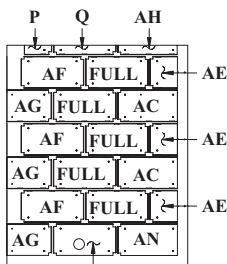

Figure 21 - Installing Brick "AO" or "AR"

BRICK INSTALLATION FOR MODEL (V)JM36

LEFT PANEL



REAR PANEL

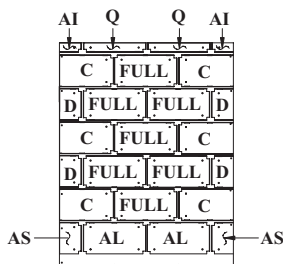

RIGHT PANEL

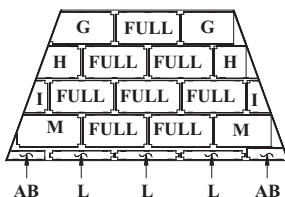
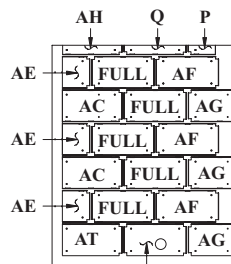

HEARTH PANEL

**See instruction above before installing brick "AR"

BRICK INSTALLATION

Continued

BRICK INSTALLATION FOR MODEL (V)JM42

LEFT PANEL

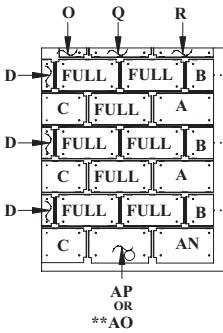

REAR PANEL

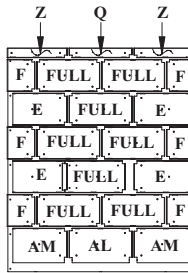

RIGHT PANEL

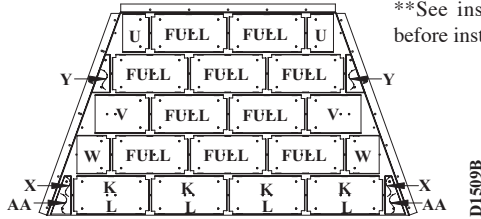
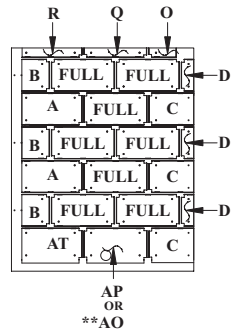

**See instruction on page 14 before installing brick "AO"

HEARTH PANEL

BRICK INSTALLATION FOR MODEL (V)JM50

LEFT PANEL

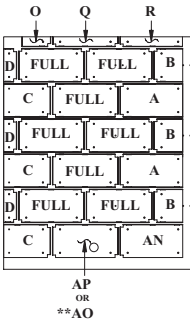

REAR PANEL

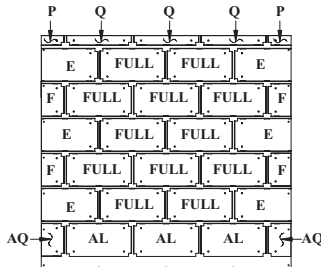

RIGHT PANEL

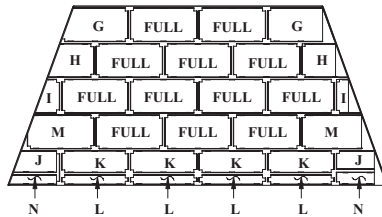
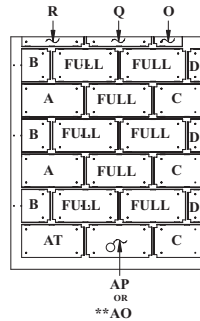

**See instruction on page 14 before installing brick "AO"

HEARTH PANEL

BRICK INSTALLATION

Continued

BRICK MATRIX - (V)JM36

BRICK MATRIX FOR MODEL (V)JM36																	
BRICK MATRIX	Full	A	B	C	D	E	F	G	H	I	J	K	L	M	N	O	P
Box #1 Hearth-36	8	-	-	-	-	-	-	2	2	2	-	-	3	2	-	-	-
Box #2 Rear-36	7	-	-	6	4	-	-	-	-	-	-	-	-	-	-	-	-
Box #3 Left or Right-36	5	-	-	-	-	-	-	-	-	-	-	-	-	-	-	-	1
Box #4 Left or Right-36	5	-	-	-	-	-	-	-	-	-	-	-	-	-	-	-	1
TOTAL	25	0	0	6	4	0	0	2	2	2	0	0	3	2	0	0	2

BRICK MATRIX FOR MODEL (V)JM36 (Continued)														
BRICK MATRIX	Q	R	S	T	U	V	W	X	Y	Z	AA	AB	AC	AD
Box #1 Hearth-36	-	-	-	-	-	-	-	-	-	-	-	2	-	-
Box #2 Rear-36	2	-	-	-	-	-	-	-	-	-	-	-	-	-
Box #3 Left or Right-36	1	-	-	-	-	-	-	-	-	-	-	-	2	-
Box #4 Left or Right-36	1	-	-	-	-	-	-	-	-	-	-	-	2	-
TOTAL	4	0	0	0	0	0	0	0	0	0	0	2	4	0

BRICK MATRIX FOR MODEL (V)JM36 (Continued)													
BRICK MATRIX	AE	AF	AG	AH	AI	AJ	AK	AL	AM	AN	AO	AP	AQ
Box #1 Hearth-36	-	-	-	-	-	-	-	-	-	-	-	-	-
Box #2 Rear-36	-	-	-	-	2	-	-	2	-	-	-	-	-
Box #3 Left or Right-36	3	3	3	1	-	-	-	-	-	1	-	1	-
Box #4 Left or Right-36	3	3	3	1	-	-	-	-	-	-	-	1	-
TOTAL	6	6	6	2	2	0	0	2	0	1	0	2	0

BRICK MATRIX FOR MODEL (V)JM36 (Continued)				
BRICK MATRIX	AR	AS	AT	TOTAL
Box #1 Hearth-36	-	-	-	21
Box #2 Rear-36	-	2	-	25
Box #3 Left or Right-36	1	-	-	22
Box #4 Left or Right-36	1	-	1	22
TOTAL	2	2	1	90

BRICK INSTALLATION

Continued

BRICK MATRIX - (V)JM42

BRICK MATRIX FOR MODEL (V)JM42																	
BRICK MATRIX	Full	A	B	C	D	E	F	G	H	I	J	K	L	M	N	O	P
Box #1 Hearth-42	10	-	-	-	-	-	-	-	-	-	-	4	4	-	-	-	-
Box #2 Rear-42	8	-	-	-	-	4	6	-	-	-	-	-	-	-	-	-	-
Box #3 Left or Right-42	8	2	3	3	3	-	-	-	-	-	-	-	-	-	-	1	-
Box #4 Left or Right-42	8	2	3	3	3	-	-	-	-	-	-	-	-	-	-	1	-
TOTAL	34	4	6	6	6	4	6	0	0	0	0	4	4	0	0	2	0

BRICK MATRIX FOR MODEL (V)JM42 (Continued)														
BRICK MATRIX	Q	R	S	T	U	V	W	X	Y	Z	AA	AB	AC	AD
Box #1 Hearth-42	-	-	-	-	2	2	2	2	2	-	2	-	-	-
Box #2 Rear-42	1	-	-	-	-	-	-	-	-	-	-	-	-	-
Box #3 Left or Right-42	1	1	-	-	-	-	-	-	-	-	-	-	-	-
Box #4 Left or Right-42	1	1	-	-	-	-	-	-	-	-	-	-	-	-
TOTAL	3	2	0	0	2	2	2	2	2	0	2	0	0	0

BRICK MATRIX FOR MODEL (V)JM42 (Continued)													
BRICK MATRIX	AE	AF	AG	AH	AI	AJ	AK	AL	AM	AN	AO	AP	AQ
Box #1 Hearth-42	-	-	-	-	-	-	-	-	-	-	-	-	-
Box #2 Rear-42	-	-	-	-	-	-	-	1	2	-	-	-	-
Box #3 Left or Right-42	-	-	-	-	-	-	-	-	-	1	1	1	-
Box #4 Left or Right-42	-	-	-	-	-	-	-	-	-	-	1	1	-
TOTAL	0	0	0	0	0	0	0	1	2	1	2	2	0

BRICK MATRIX FOR MODEL (V)JM42 (Continued)				
BRICK MATRIX	AR	AS	AT	TOTAL
Box #1 Hearth-42	-	-	-	30
Box #2 Rear-42	-	-	-	24
Box #3 Left or Right-42	-	-	-	25
Box #4 Left or Right-42	-	-	1	25
TOTAL	0	0	1	104

BRICK INSTALLATION

Continued

BRICK MATRIX - (V)JM50

BRICK MATRIX FOR MODEL (V)JM50																	
BRICK MATRIX	Full	A	B	C	D	E	F	G	H	I	J	K	L	M	N	O	P
Box #1 Hearth-50	12	-	-	-	-	-	-	2	2	2	2	4	4	2	2	-	-
Box #2 Rear-50	12	-	-	-	-	6	4	-	-	-	-	-	-	-	-	-	2
Box #3 Left or Right-50	8	2	3	3	3	-	-	-	-	-	-	-	-	-	-	1	-
Box #4 Left or Right-50	8	2	3	3	3	-	-	-	-	-	-	-	-	-	-	1	-
TOTAL	40	4	6	6	6	6	4	2	2	2	2	4	4	2	2	2	2

BRICK MATRIX FOR MODEL (V)JM50 (Continued)														
BRICK MATRIX	Q	R	S	T	U	V	W	X	Y	Z	AA	AB	AC	AD
Box #1 Hearth-50	-	-	-	-	-	-	-	-	-	-	-	-	-	-
Box #2 Rear-50	3	-	-	-	-	-	-	-	-	-	-	-	-	-
Box #3 Left or Right-50	1	1	-	-	-	-	-	-	-	-	-	-	-	-
Box #4 Left or Right-50	1	1	-	-	-	-	-	-	-	-	-	-	-	-
TOTAL	5	2	0	0	0	0	0	0	0	0	0	0	0	0

BRICK MATRIX FOR MODEL (V)JM50 (Continued)													
BRICK MATRIX	AE	AF	AG	AH	AI	AJ	AK	AL	AM	AN	AO	AP	AQ
Box #1 Hearth-50	-	-	-	-	-	-	-	-	-	-	-	-	-
Box #2 Rear-50	-	-	-	-	-	-	-	3	-	-	-	2	-
Box #3 Left or Right-50	-	-	-	-	-	-	-	-	-	1	1	-	-
Box #4 Left or Right-50	-	-	-	-	-	-	-	-	-	-	1	-	-
TOTAL	0	0	0	0	0	0	0	3	0	1	2	2	0

BRICK MATRIX FOR MODEL (V)JM50 (Continued)				
BRICK MATRIX	AR	AS	AT	TOTAL
Box #1 Hearth-50	-	-	-	32
Box #2 Rear-50	-	-	-	32
Box #3 Left or Right-50	-	-	-	25
Box #4 Left or Right-50	-	-	1	25
TOTAL	0	0	1	114

BRICK INSTALLATION

Continued

INSTALLING Z-SHAPED GRATE RETAINER BRACKET

Before grouting the bricks, locate the z-shaped grate retainer brackets on top of the hearth bricks as shown in Figure 22. Position the retainer brackets at 8 3/4" apart from center to center of notch.

Model	Distance Apart
JM36	3 1/4" Centers
JM42	4 1/4" Centers
JM50	8 3/4" Centers

See Chart for Grate Retainer Brackets Location

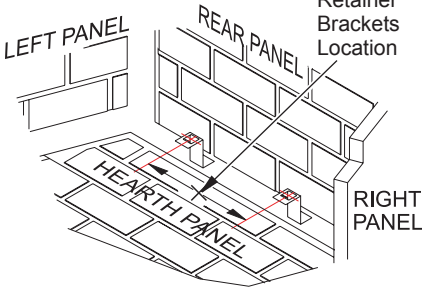

Figure 22 - Installing Grate Retainer Bracket

GROUTING INSTRUCTIONS

Material provided:

2 - 9 lb. bags of cement

2 - 9 lb. bags of sand

Material required:

1 - Piping bag

1 - Joints striker

1 - Heavy duty mixing bucket

1 - Trowel

1. Moisten brick surface with a damp sponge or a spray bottle just prior to application. When the bricks are wet, any excess grout mixture that might have gotten onto the brick will easily wipe off.
2. In a heavy duty mixing bucket, pour seven (7) cups of water in first, then add in 4.5 lbs. (half of a bag) of sand and 4.5 lbs (half of a bag) of cement. Mix together well using a power drill with a mixing wand attachment.
3. The overall length of piping bag should be about 16". If the bag is longer than 16", cut it down to size by removing end with larger opening. This will make the bag easier to handle.

4. Put 2 to 3 cups of grout mixture into piping bag making sure the smaller opening is downward and over a moist towel to avoid spilling. Place a wet towel over the bucket making sure it is directly on the surface of grout mixture. This will keep the mixture moist and it will not dry out before use.
5. Begin grouting by first doing a "Filler Pass". This is done by filling the joint about 3/4 full with grout mixture. It is important to work with only 6 bricks at a time so grout doesn't have time to set up before striking.
6. Complete a "Finishing Pass" around 6 bricks you just put filler pass around. This is done by slowly filling in remainder of the joint with a thick amount of grout mixture. Mixture should be a little higher than the brick surface.
7. Using a trowel, remove excess grout mixture by moving trowel in the direction of the joint. Grout mixture in the joint should now be flush with brick surface.
8. Using a Joint Striker, force grout mixture into joint and sweep back and forth until grout is smooth and round. If grout becomes too shallow, add more grout mixture with piping bag and strike again.
9. Continue procedure around each group of 6 bricks until an entire panel is finished.
10. Using trowel, scrape in direction of joints to remove any grout that may have collected around bricks during striking. If desired, take a moist sponge and lightly sweep over bricks to remove any grout that may have gotten on bricks. **DO NO PRESS HARD OR RUB IN A CIRCULAR MOTION.** This will press the grout into brick and turn brick a different color.

Allow 72 hours before operating fireplace.



Figure 23 - Grouting Brick

GLASS DOOR INSTALLATION

IMPORTANT: Install glass door frame before installing glass door.

DOOR MODELS BDM36E/G/C, BDM42E/G/C AND BDM50E/G/C

Assembly

Insert L-shaped gussets starting at the left top portion of door frame. Gusset holes should align with screw holes on the frame. Secure using flat head screws.

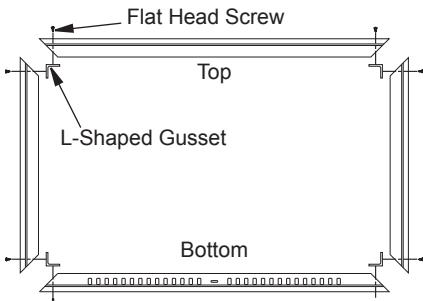
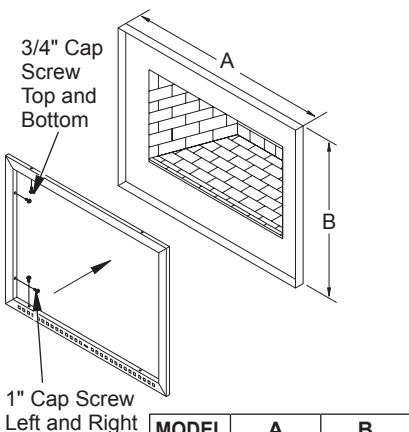

Figure 24 - Assembling Door Frame

Installation

To install glass door frame, construct an opening (see table) on the front face of the fireplace. Insert door frame into face opening and tighten screws (see Figure 25).



MODEL	A	B
JM36	37"±1/4"	34"±1/4"
JM42	43"±1/4"	34"±1/4"
JM50	51"±1/4"	34"±1/4"

Figure 25 - Installing Door Frame

DOOR FRAME MODELS BDMO36E/G/C, BDMO42E/G/C AND BDMO50E/G/C

Installation

1. Remove screws from smoke shelf (see Figure 26).
2. Mount top door frame and secure with screws provided (see Figure 26).
3. Place bottom door frame on top of ash lip at front of fireplace (see Figure 27).
4. Secure bottom door frame to brick with two hex screws provided as shown in Figure 27 using a 7/16" open end or adjustable wrench.

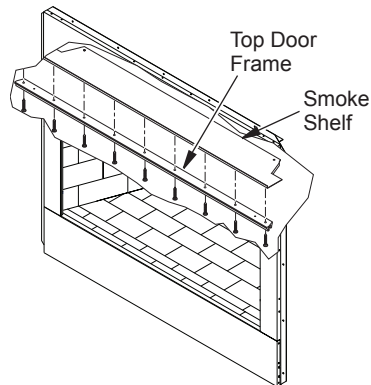

Figure 26 - Installing Top Door Frame

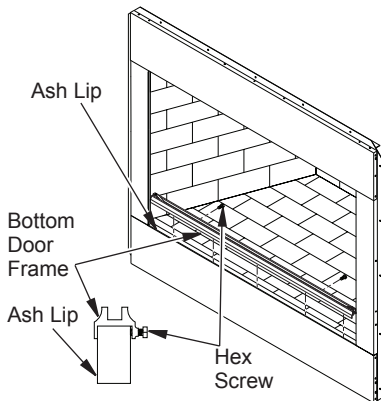

Figure 27 - Installing Bottom Door Frame

GLASS DOOR INSTALLATION

Continued

INSTALLING GLASS DOORS

Spring clips have been installed but some adjustments may be needed. Install the doors using the following steps:

1. With bi-fold doors completely folded, insert bottom pivot pin into pivot hole located near bottom corner of front face opening and swing door to vertical position making sure top pins slide into door track. Door is installed when top door pin snaps into spring clip.
2. Repeat step 1 for remaining door.

If you find the doors do not close properly or do not appear level or straight, proceed with section on door adjustment,

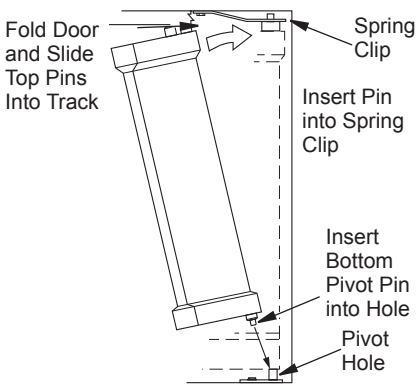

Figure 28 - Installing Bi-Fold Doors

DOOR ADJUSTMENT

Remove doors and slightly loosen lower pivot clips and upper spring clips. Replace doors and fully close them. Use 1/8" shims (any material) to level doors. Once proper setting is achieved, carefully open doors enough so that you can access spring clips with a phillips screwdriver. Tighten screws. See Figure 29.

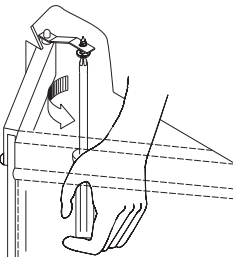

Figure 29 - Adjusting Bi-Fold Doors

OPERATION AND MAINTENANCE GUIDELINES

GLASS DOORS

Glass doors are optional with the fireplace. When fireplace is in operation, doors must be fully opened or fully closed position only or a fire hazard may be created (see Figure 30).

A fireplace equipped with glass doors operates much differently than a fireplace with an open front. A fireplace with glass doors has a limited amount of air for combustion.

Excessive heat within the fireplace can result if too large a fire is built or if combustion air gate is not completely open. The following tips should be followed to assure that both the fireplace and glass door retain their beauty and function properly. Both the flue damper and glass doors must be fully opened before starting fire. This will provide sufficient combustion air and maintain safe temperatures in firebox.

IMPORTANT: The glass must be allowed to warm slowly and evenly. The tempered glass will withstand a gradual temperature rise to 550° F, which is more than a normal fire will generate. Such materials as pitch/wax laden logs, very dry mill end lumber and large amounts of paper or cardboard boxes can create an excessively hot fire and should not be burned in this fireplace. Always keep the fire well back from the doors and never allow flames to contact the glass.

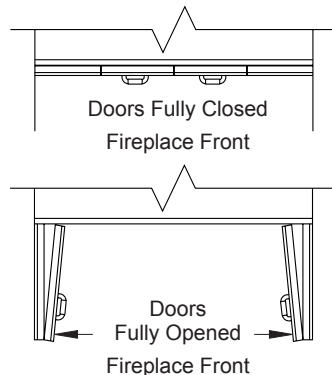

Figure 30 - Bi-Fold Glass Doors

OPERATION AND MAINTENANCE GUIDELINES

Continued

⚠ WARNING: Fireplaces equipped with glass doors should be operated only with doors fully opened or doors fully closed. Doors, if left partly open, may draw gas and flame out of the fireplace opening creating risks of both fire and smoke.

Cleaning Glass

Clean glass with any commercial glass cleaner or soap and water. Do not use any abrasive material to clean glass. Do not clean glass with any cool water if glass is still hot from the fire and smoke.

A gas line or gas log lighter may be installed for the purpose of installing a vented or vent-free decorative gas appliance incorporating an automatic shutoff device and complying with the *Standard for Decorative Gas Appliances for Installation in Vented Fireplaces, ANSI Z21.60* or *American Gas Association draft requirements for Gas Fired Log Lighters for Wood Burning Fireplaces, Draft NO. 4* dated August, 1993.

If you wish to install an unvented (vent-free) gas log set, only unvented gas log sets which have been found to comply with the standard for unvented room heaters, ANSI Z21.11.2 are to be installed in this fireplace.

OUTSIDE AIR AND DAMPER HANDLE OPERATION

The damper handle, which opens and closes the damper blade, is located in the upper front face of the fireplace. Pushing the handle forward and up through the keyway slot will free damper blade to automatically open. Pushing the handle forward and down will lock damper blade closed (see Figure 31).

The outside air kit lever is located at the left and right hand sides of fireplace (see Figure 32). Lifting lever up will free the outside air door to open. Pulling lever down will lock the door.

⚠ WARNING: Risk of fire! Replace grate with DESA model 117544-03 JM36, 117544-01 JM42, 117544-02 JM50 grate only. This grate has been designed to keep the operation of your fireplace safe and efficient.

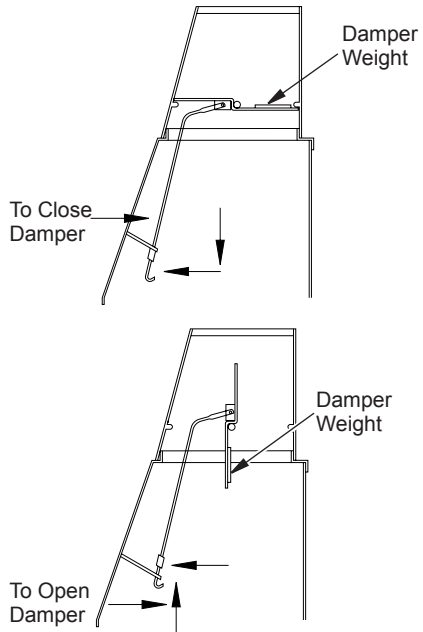

Figure 31 - Operating Damper Handle

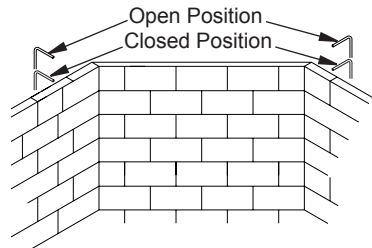

Figure 32 - Outside Air Kit Lever

TECHNICAL SERVICE

You may have further questions about installation, operation, or troubleshooting. If so, contact DESA's Technical Service Department at 1-866-672-6040.

When calling please have your model and serial numbers of your heater ready.

You can also visit DESA's technical services web site at www.desatech.com.

REPLACEMENT AND ACCESSORY PARTS

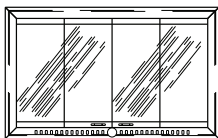

BI-FOLD GLASS MASONRY DOOR

BDM36E - 36" Ebony
BDM36G - 36" Pewter
BDM36C - 36" Oiled Bronze
BDM42E - 42" Ebony
BDM42G - 42" Pewter
BDM42C - 42" Oiled Bronze
BDM50E - 50" Ebony
BDM50G - 50" Pewter
BDM50C - 50" Oiled Bronze

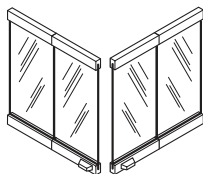

BDMO36E - 36" Ebony
BDMO36G - 36" Pewter
BDMO36C - 36" Oiled Bronze
BDMO42E - 42" Ebony
BDMO42G - 42" Pewter
BDMO42C - 42" Oiled Bronze
BDMO50E - 50" Ebony
BDMO50G - 50" Pewter
BDMO50C - 50" Oiled Bronze

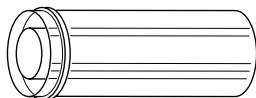

DOUBLE WALL PIPE - 12-12DM,
18-12DM, 24-12DM, 36-12DM, 48-12DM,
12-12HT, 18-12HT, 24-12HT, 36-12HT and
48-12HT

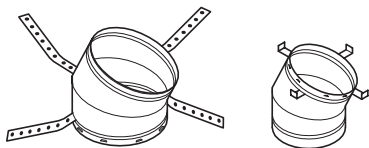

30° OFFSET AND RETURN
30E-12DM and 30E-12HT

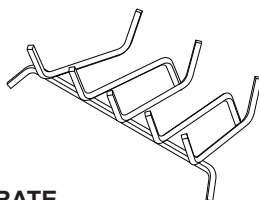

GRATE

117544-03 - Model JM36
117544-01 - Model JM42
117544-02 - Model JM50

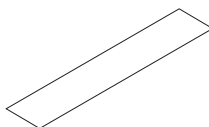

EMBER PROTECTOR - EP36

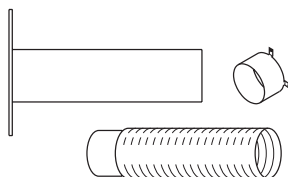

OPTIONAL OUTSIDE AIR KIT FOR FLOOR INSTALLATION - AK4F

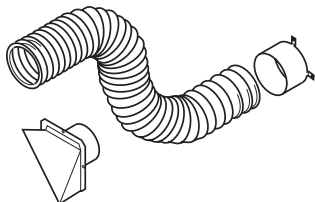

OPTIONAL OUTSIDE AIR KIT FOR SIDEWALL INSTALLATION - AK-4 PN 01576



STORM COLLAR - SC2-1

REPLACEMENT AND ACCESSORY PARTS

Continued

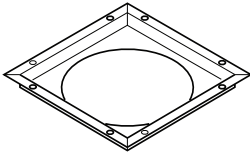

FIRESTOP SPACER - FS-10
(1100EFS-10DM FOR MODEL GM36)

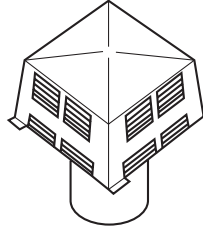

**SQUARE CHASE-TOP
TERMINATION - STL-12D**

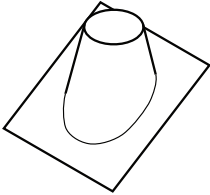

ROOF FLASHING
V6F-10DM - 0 to 6/12 Pitch
V12F-10DM - 6/12 to 12/12 Pitch

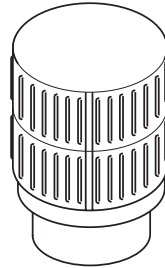

**ROUND TOP TERMINATIONS
RLT-12D AND RLT-12HT**



2701 Industrial Drive
P.O. Box 90004
Bowling Green, KY 42102-9004
www.desatech.com



117541 01
NOT A UPC

117541-01
Rev. B
11/05