

FDV350

DIRECT VENT FREE STANDING GAS STOVE



The Ultimate in Design, Engineering & Quality

This unit illustrated is a FDV350N Direct Vent Natural Gas Stove, with F35DG Gold Door and Ceramic Glass and LOGF35 Fibre Oak Log Set with embers.

Direct Vent Free Standing Stove; a Safe and Efficient Heating Appliance with the Convenience of Gas.

YOUR BEST CHOICE FOR INSTALLATION ANYWHERE THROUGHOUT YOUR HOME.

MODEL	FDV350N	FDV350LP
FUEL	NATURAL	PROPANE
INPUT LOW	29,000 BTU	27,000 BTU
INPUT HIGH	37,000 BTU	35,000 BTU
EFFICIENCY	84%	85%
FE (P.4.1-02)	67.1%	69.7%

FEATURES*

- Millivolt Valve with Hi-Low heat and flame adjustment and allows operation during a power failure
- Dual burner system, with realistic flame pattern
- Heat radiating ceramic glass with panoramic view from three sides
- Mobile home approved
- Approved for installation in a bedroom or bed sitting room
- Black Louver
- Fibre Oak Log Set with Embers*



OPTIONAL FEATURES

- Heat activated blower with variable speed control
- Brick refractory liner (3 pieces)
- Designer Black Arch Door with Ceramic Glass
- Designer Gold Arch Door with Ceramic Glass
- Gold (24 carat) Louver
- Thermostat – Wall Mount Millivolt Thermostat or Programmable Thermostat
- Remote Control – On/Off, Thermostat or Hi/Lo On/Off

MINIMUM CLEARANCES TO COMBUSTIBLES:

- 12" from side of unit
- 3" from back of unit
- 3" from side of unit in corner

ALCOVE INSTALLATION:

- 30" depth (max.)
- 55 1/2" height (min.)
- 52 1/2" width (min.)

DIMENSIONS AND SIZING

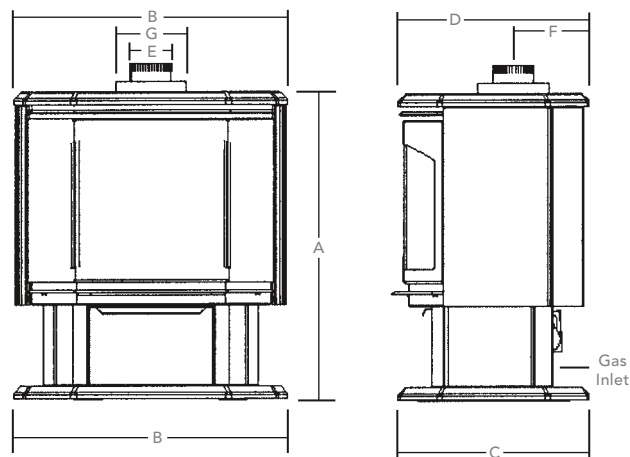

A	30 ³ / ₈ "
B	27 ⁵ / ₁₆ "
C	19 ¹ / ₁₆ "
D	19 ¹ / ₁₆ "
E	4" diameter
F	7 ¹ / ₂ "
G	7" diameter

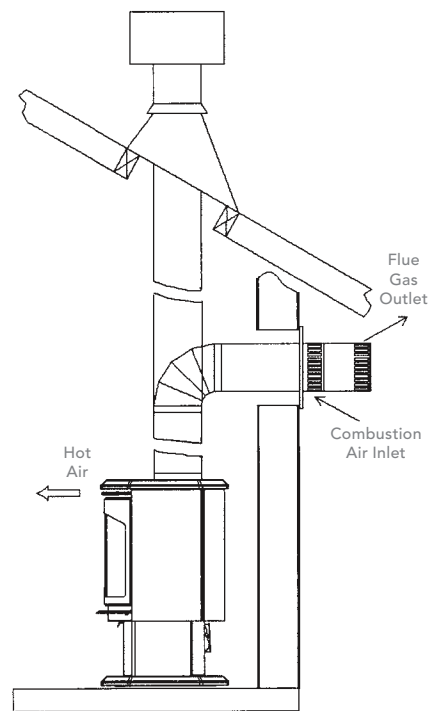

With a direct vent appliance you can vent either through the side wall above the unit or straight up through the roof.



Kingsman Industries maintains a program of continuous testing, refinement and improvements of all its products. Some aspect of units shown here may be changed at any time without notice or obligation.

Certification: The model FDV350 is certified for USA and Canada, Certified to: ANSI Z21.88a-1999/CSA-2.33a-M99, Can/CGA 2.17-1991, CR89-001, CSA P.4.1-02. Listed Direct Vent Gas Fired Free Standing Room Heater

*Components may have to be ordered separately to create a complete unit. Discuss with your local Kingsman dealer for clarification.



2340 Logan Avenue
Winnipeg, Manitoba, Canada R2R 2V3
Phone: (204) 632-1962 Fax: (204) 632-1960
www.kingsmanfireplaces.com