

Installation Instructions

Model Number ZDV3318/3622

Zero Clearance Direct Vent Gas Fireplace

Stock #'s: ZDV3318N, ADV3318LP, ZDV3622N and ZDV3622LP are
Certified to: ANZI Z21.88-2009, CSA 2.33-2009, CGA 2.17-M91
Vented Gas Fireplace Heaters, For Use At High Altitudes



INSTALLER: Leave this manual with the appliance.
CONSUMER: Retain this manual for future reference.

This appliance may be installed in an aftermarket permanently located, manufactured home (USA only) or mobile home, where not prohibited by local codes.
This appliance is only for use with the type of gas indicated on the rating plate. This appliance is not convertible for use with other gases, unless a certified kit is used.

Read this complete manual before beginning installation.
These instructions must be kept with the unit for future reference.

FOR YOUR SAFETY



WARNING: If the information in these instructions is not followed exactly, a fire or explosion may result causing property damage, personal injury or loss of life.



WARNING: Improper installation, adjustment, alteration, service or maintenance can cause property damage, personal injury or loss of life. Refer to this manual. Installation and service must be performed by a qualified installer, service agency or the gas supplier.

Do not store or use gasoline or other flammable vapors and liquids in the vicinity of this or any other appliance.

What to Do If You Smell Gas

- Do not try to light any appliance.
- Extinguish any open flame.
- Do not touch any electrical switch.
- Do not use any phone in your building.
- Immediately call your gas supplier from a neighbour's phone.
- If you can not reach your gas supplier, call the fire department.

For Propane Horizontal installations the venting must be a minimum of one foot vertical off the flue before going horizontal.



A Division of R-Co. Inc.
2340 Logan Avenue
Winnipeg, Manitoba, Canada R2R 2V3
Ph: (204) 632-1962

PRE-INSTALLATION QUESTIONS and ANSWERS

Why does my fireplace or stove give off odour?

It is normal for your fireplace to give off some odour. This is due to the curing of the paint, adhesives, silicones and any undetected oil from the manufacturing process as well as the finishing materials used with the installations (e.g. marble, tile and the adhesives used to adhere this product to the walls can react with heat and cause odours).

It is recommended that you burn your gas fireplace or stove for a minimum of four hours at a time with the fan off after the curing of the paint has been completed. These odours can last upward to 40 hours of burn time, keep burning at a minimum of four hours per use until odours dissipate.

About curing of the paint

Your stove or fireplace has been painted with the highest quality silicone stove paint. This paint dries quickly in 15-20 minutes when first applied at the factory. However, due to the high temperature silicone components, the paint will cure when heat is applied to the appliance as it is first used.

The following information **applies to the curing process** to get the paint fully hard and durable.

Fire the appliance four successive times for 10 minutes each firing and a 5 minute cool down between each. Be aware during log and firebox paint curing that a white deposit may be developing on the inside of the glass doors. It is important to remove this white deposit from the glass doors with an appropriate cleaner to prevent build-up (such as Windex or a commercial fireplace glass cleaner).

- Babies, small children, pregnant women and pets should leave the area during the cure phase.
- Ventilate well, open doors and windows.
- Do not touch during curing.

Noise coming from the fireplace?

- Noise caused by metal expanding and contracting as it heats up and cools down, similar to the sound produced by a furnace or heating duct. This noise does not affect the operation or longevity of your fireplace.
- Different types and thicknesses of steel will expand and contract at different rates resulting in “cracking” and “ticking” sounds throughout the heating and cooling periods.
- You should also be aware that as temperatures change within the unit these sounds will likely re-occur. Again this is normal for steel fireboxes, and is not a defect.

Cleaning the Glass

During the first few fires, a white film may develop on the glass front, as part of the curing process. The glass should be cleaned after the unit has cooled down or the film can bake on and become very difficult to remove. Use a non-abrasive cleaner and do not attempt to clean the glass while it is hot.

Table of Contents

Pre-Installation Questions and Answers	2
Table of Contents	3
Mobile Home/Manufactured Housing Installation	4
Warnings, Installations & Operations	5
Operations & Maintenance Instructions	6
Installation Requirements for the Commonwealth of Massachusetts	6
ZDV3318	
Locating your appliance	7
Fireplace Dimensions	7
Framing your gas fireplace	8
Framing & Facing Requirements	9
ZDV3622	
Locating you appliance	10
Fireplace Dimensions	10
Framing your gas fireplace	11
Framing & Facing Requirements	12
Installing Clean View Kit (CVCK)	13
Clearances to Combustibles Diagram	14
Mantel Leg Clearances	15
Clearance to Combustibles Specifications	16
Dimensions & Installation of Wall Mount Surrounds	17
Fan Installation	18
Brick Installation	19
Porcelain Panel Installation Guide	20
General Glass Information	21
Gas Line Installation	21
Millivolt system, lighting, & burner control	22
Installation of Gas Conversion Kit for Top Convertible Pilot	23
IPI Electronic Ignition System	24-28
IPI Lighting Instructions	29
Trouble shooting the gas control system	30
Log C50 Log Placement Guide	31-32
Vent termination	33
General vent installation information	34
Installation of side wall venting	34
Installation of venting straight up through Roof	35-36
Vertical Venting of 15 Feet	37
ZDV3318 Parts List	38
ZDV3622 Parts List	39
Common parts list	40
Limited Lifetime Warranty	41

Mobile Home/Manufactured Housing Installation

This Direct Vent System Appliance must be installed in accordance with the manufacturer's installation instructions and the Manufactured Home Construction and Safety Standard Title 24 CFR, Part 3280, or the current Standard for Fire Safety Criteria for Manufactured Home Installations, Sites, and Communities ANSI/NFPA 501A, and with CAN/CSA Z240 MH Mobile Home Standard in Canada.

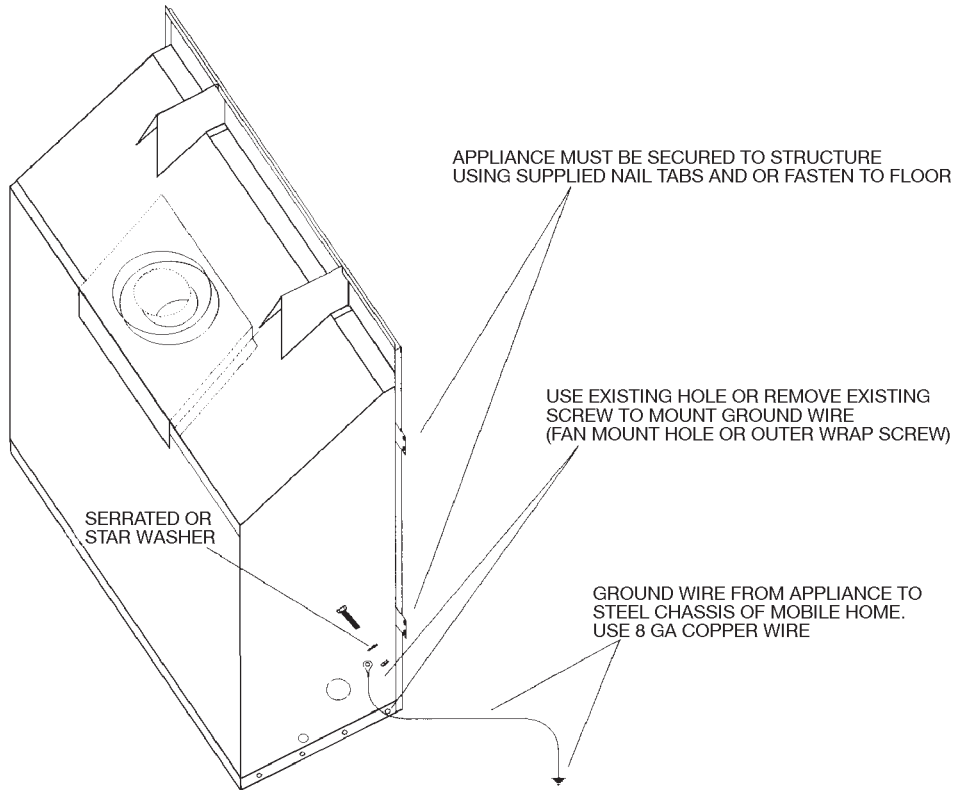

THE ZDV3318, ZDV3318LP, ZDV3622N and ZDV3622LP MAY BE INSTALLED IN MANUFACTURED (MOBILE) HOMES AFTER FIRST SALE IN THE USA. IN CANADA THE ZDV3318, ZDV3318LP, ZDV3622N and ZDV3622LP MAY BE INSTALLED IN MANUFACTURED (MOBILE) HOMES.

Please follow the current ANSI/NFPA 70 National Electrical Code in the USA and CAN/CSA C22.1 Canadian National Electrical Code in Canada.

An appliance must be grounded to the steel chassis of the home with 8 ga. copper wire using a serrated or star washer to penetrate paint or protective coating to insure grounding.

Use carriage bolt at the attachment point (see diagram above) to secure the appliance to the floor.



Warning: Do not compromise the structural integrity of the manufactured home wall, floor or ceiling, during installation of appliance or venting.

For required venting components see venting installation in appropriate section of this manual.

Certified for installation in a bedroom or bed/sitting room. In Canada must be installed with listed milli volt thermostat. In USA see local codes.

Warnings, Installations, and Operations

Installation Regulations

This gas appliance must be installed by a qualified installer in accordance with local building codes, or in the absence of local codes, with the current CAN/CGA-B149.1 Installation Code (in Canada) or the current National Fuel Gas Code Z223.1 when installed in the United States.

This appliance, when installed, must be electrically connected and grounded in accordance with local codes, or in the absence of local codes, with the current CSA C22.1 Canadian Electrical Code or with the national Electrical Code; ANSI/NFPA 70-1987 when installed in the United States.

Warning

FOR SAFE INSTALLATION AND OPERATION OF YOUR GAS FIREPLACE PLEASE NOTE THE FOLLOWING:

1. Do not clean when the glass is hot.
2. Do not use abrasive cleaners.
3. Using a substitute glass will void all product warranties.
4. For safe operation, glass doors must be closed.
5. When purging the gas line, the glass front must be removed.
6. Do not strike or abuse glass. Take care to avoid breakage.
7. Do not alter gas orifice.
8. No substitute materials may be used other than factory supplied components.
9. This appliance gives off high temperatures and should be located out of heavy traffic areas and away from furniture and draperies.
10. Children and adults should be alerted to the hazards of the high surface temperatures of this appliance and should stay away to avoid burns or ignition of clothing.
11. Young children should be carefully supervised when they are in the same room as the appliance. Toddlers, young children and others may be susceptible to accidental contact burns. A physical barrier is recommended if there are at risk individuals in the house. To restrict access to a fireplace or stove, install an adjustable safety gate to keep toddlers, young children and other at risk individuals out of the room and away from hot surfaces.
12. Under no circumstances should any solid fuels (wood, paper) be used in this appliance.
13. Under no circumstances should this appliance be modified. Any parts that have to be removed for servicing should be replaced prior to operating this appliance.
14. Installation and repair should be done by a qualified service person. The appliance should be inspected before use and at least annually by a professional service person. More frequent cleaning may be required due to excessive lint from carpeting, bedding material, et cetera. It is imperative that control compartments, burners and circulating air passageways of the appliance be kept clean. Make sure that the gas valve and pilot light are turned off before you attempt to clean this unit.
15. Clothing or other flammable material should not be placed on or near the appliance. This appliance should not be used as a drying rack for clothing nor should Christmas stockings or decorations be hung from it.
16. Do not use this heater if any part has been under water. Immediately call a qualified service technician to inspect the heater and to replace any part of the control system and any gas control which has been under water.
17. Do not operate appliance unless completely installed as per installation instructions.
18. Failure to position the parts in accordance with these diagrams or failure to use only parts specifically approved with this appliance may result in property damage or personal injury.
19. Do not operate appliance with the glass front removed, cracked or broken. Replacement of the glass should be done by a licensed or qualified service person.
20. The front of the fireplace gives off high temperatures that could ignite combustible material which is kept close to the front of the unit.
21. Ensure that power to the Fireplace is turned off before servicing.
22. Do not operate this Fireplace without the glass front or with a broken glass.
23. Improper installation, adjustment, alteration, service or maintenance can cause injury or property damage. Refer to the owner's information manual provided with this appliance. For assistance or additional information consult a qualified installer, service agency, or the gas supplier.
24. Operation of this appliance when not connected to a properly installed and maintained venting system or tampering with the blocked vent shutoff system can result in carbon monoxide (CO) poisoning and possible death.



- Gas fired appliances may be used only for supplemental heat and/or decorative purposes and under no circumstances shall they provide a primary heat source.
- This appliance must not be connected to a chimney flue serving a separate solid-fuel burning appliance.

NOTE: It is recommended that a Carbon Monoxide (CO) Detector be installed in or near bedrooms and on all levels of your home. Place a detector about 15ft [4.5m] outside the room that houses your gas appliance.
 Certified for installation in a bedroom or bed/sitting room. In Canada must be installed with listed millivolt thermostat. In USA see local codes.

Operations and Maintenance Instructions

For safe installation and operation note the following:

- The Burner/Log Assembly has been engineered and permanently adjusted for proper flame control.
- Periodically remove the logs from the grate assembly and vacuum any loose particles from the grate and burner areas. See Log Placement page to remove logs. Vacuum burner parts and replace logs.
- Label all wires prior to disconnection when servicing controls. Wiring errors can cause improper and dangerous operation.

Installation Requirements for the Commonwealth of Massachusetts

Verify proper operation after servicing.

In the Commonwealth of Massachusetts, the installer or service agent shall be a plumber or gas fitter licensed by the Commonwealth.

When installed in the Commonwealth of Massachusetts or where applicable codes; the unit shall be installed with a CO detector per the requirements listed below.

1. For direct-vent appliances, mechanical-vent heating appliances or domestic hot water equipment, where the bottom of the vent terminal and the air intake is installed below four feet above grade the following requirements must be satisfied:
 - A. If there is not one already present, on each floor level where there are bedroom(s), a carbon monoxide detector and alarm shall be placed in the living area outside the bedroom(s). The carbon monoxide detector shall comply with NFPA 720 (2005 Edition).
 - B. A carbon monoxide detector shall be located in the room that houses the appliance or equipment and shall:
 - Be powered by the same electrical circuit as the appliance or equipment such that only one service switch services both the appliance and the carbon monoxide detector;
 - Have battery back-up power;
 - Meet ANSI./UL 2034 Standards and comply with NFPA 720 (2005 Edition); and
 - Have been approved and listed by a Nationally Recognized Testing Laboratory as recognized under 527 CMR.
 - C. A Product-approved vent terminal must be used, and if applicable, a Product-approved air intake must be used. Installation shall be in strict compliance with the manufacturer's instructions. A copy of the installation instructions shall remain with the appliance or equipment at the completion of the installation.
 - D. A metal or plastic identification plate shall be mounted at the exterior of the building, four feet directly above the location of vent terminal. The plate shall be of sufficient size to be easily read from a distance of eight feet away, and read "Gas Vent Directly Below".
2. For direct-vent appliances, mechanical-vent heating appliances or domestic hot water equipment where the bottom of the vent terminal and the air intake is installed above four feet above grade the following requirements must be satisfied:
 - A. If there is not one already present, on each floor level where there are bedroom(s), a carbon monoxide detector and alarm shall be placed in the living area outside the bedroom(s). The carbon monoxide detector shall comply with NFPA 720 (2005 Edition).
 - B. A carbon monoxide detector shall:
 - Be located in the room that houses the appliance or equipment;
 - Be either hard-wired or battery powered or both; and
 - Shall comply with NFPA 720 (2005 Edition).

A Product-approved vent terminal must be used, and if applicable, a Product-approved air intake must be used. Installation shall be in strict compliance with the manufacturer instructions. A copy of the installation instructions shall remain with the appliance or equipment at the completion of the installation.

For the state of Massachusetts a **T-handle gas shut-off valve** must be used on a gas appliance. This T-handle gas shut-off valve must be listed and approved by the state of Massachusetts. This is in reference to the state of Massachusetts state code CMR238.

ZDV3318 - Locating your Appliance

Installing with Top Vent

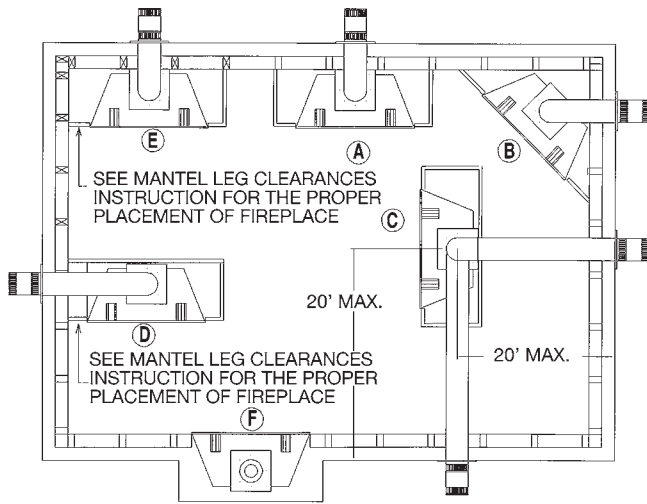

- A - Flat on a wall
- B - Across the corner
- C - As an island
- D - As a room divider
- E - Flat on wall corner
- F - Exterior wall

Island installation with a top vent is possible as long as the horizontal portion of the vent system does not exceed 20 feet (6.1 m).

ZDV3318 Fireplace Dimensions

ZDV3318 louvered

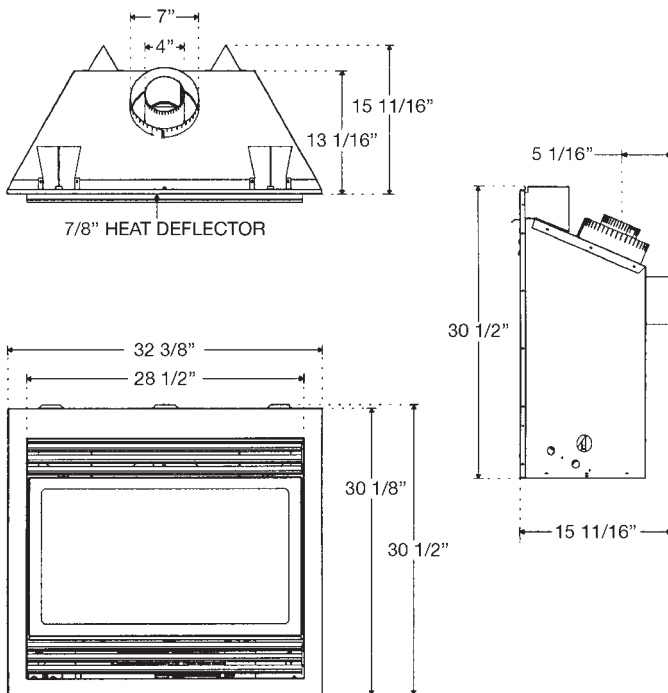

ZDV3318 -CVCK (Clean View Circulating Kit)

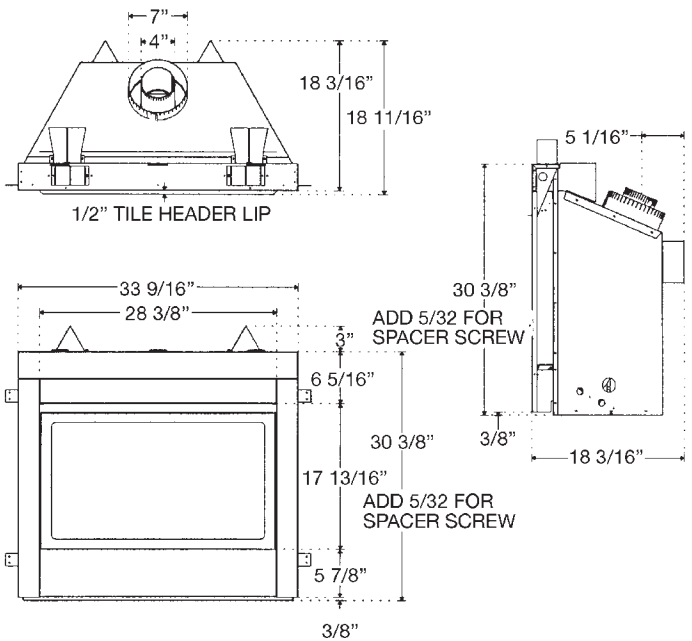

ZDV3318 - Framing for your Gas Fireplace

Framing Specifications

1. Cold climate installation recommendation: When installing this fireplace against non insulated exterior wall or chase, it is recommended that the outer walls be insulated to conform to applicable insulation codes. Drywall must be installed over insulation to prevent contact of insulation and unit.
2. Choose fireplace location and frame in accordance with the fireplace framing dimensions specified (See Framing Diagrams). Bend nailing tabs forward on left and right of unit and place fireplace into framed enclosure. This allows for 1/2" in front of framing tabs for finishing materials.
3. Drywall or other material can extend flush with the appliance on the bottom, sides and top of fireplace. (louvered models only)

4. When installing horizontal with a 90 degree bend maintain a minimum of two and a half (2.5") inches above the bend in enclosures.
5. For a fireplace with louvers combustible floor can raise 1" above the bottom of the fireplace. For a fireplace with 33CVCK (Clean view Circulating Kit) floor or hearth can raise 7" above the bottom of the fireplace with portions being combustible and non combustible. See drawing on following page.
6. When installing MQSWF surround, the fireplace must be raised a minimum of 2 7/8" above the finished floors, to accommodate the wall surround. The fireplace may be raised higher but the 60" clearance measured from the bottom of the fireplace to the ceiling must be maintained at all times. (i.e. For an 8 ft. ceiling the unit can be raised only 36 inches.)

For **Propane Horizontal Installations** the venting must be a minimum of one foot vertical off the flue before the elbow on any horizontal runs of one foot or greater. This allows for cleaner combustion and greatly reduces carboning and cleaning of glass.

ZDV3318 Louvered

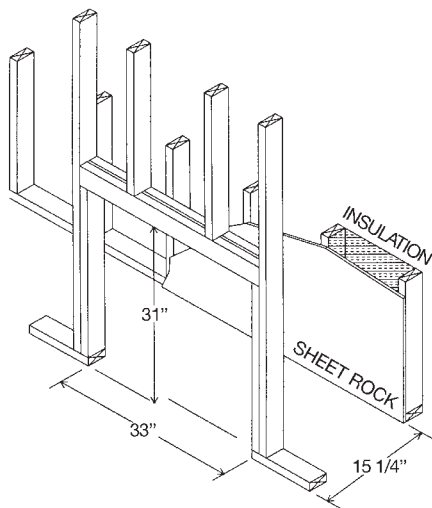
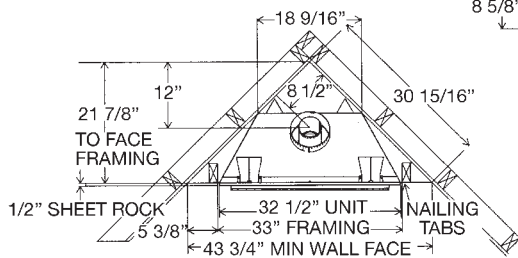
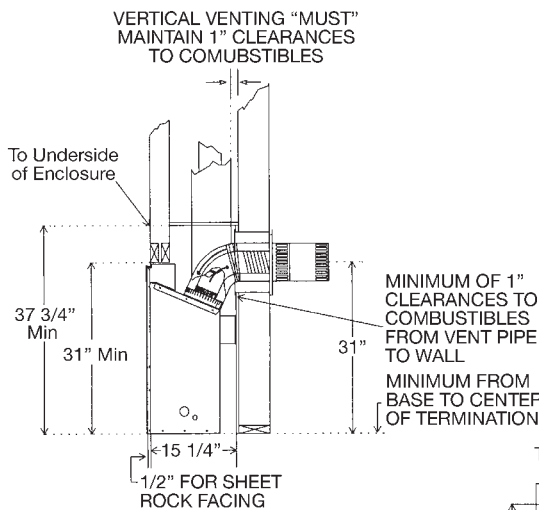

ZDV3318 WITH CVCK (CLEAN VIEW CIRCULATING KIT)

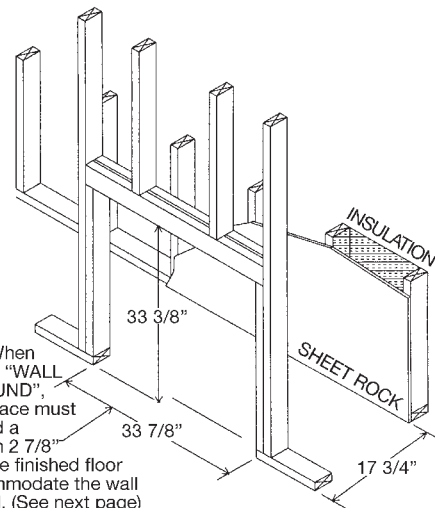
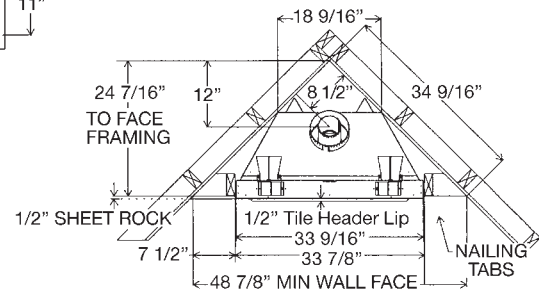
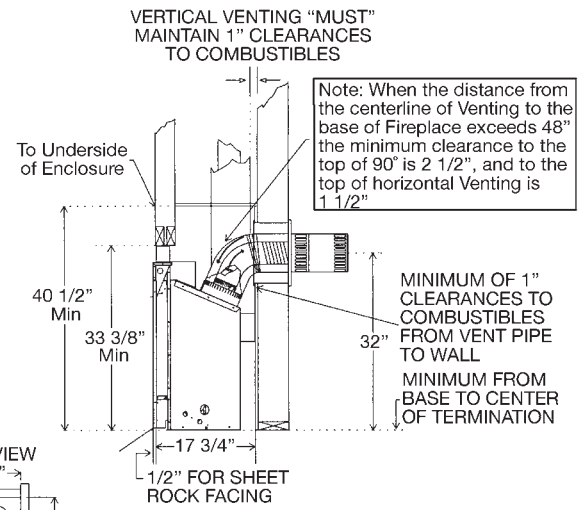

NOTE: When adding a "WALL SURROUND", the fireplace must be raised a minimum 2 7/8" above the finished floor to accommodate the wall surround. (See next page)

Z33CVCK - Framing and Facing Requirements

ZDV3318 WITH Z33CVCK (CLEAN VIEW CIRCULATING KIT)

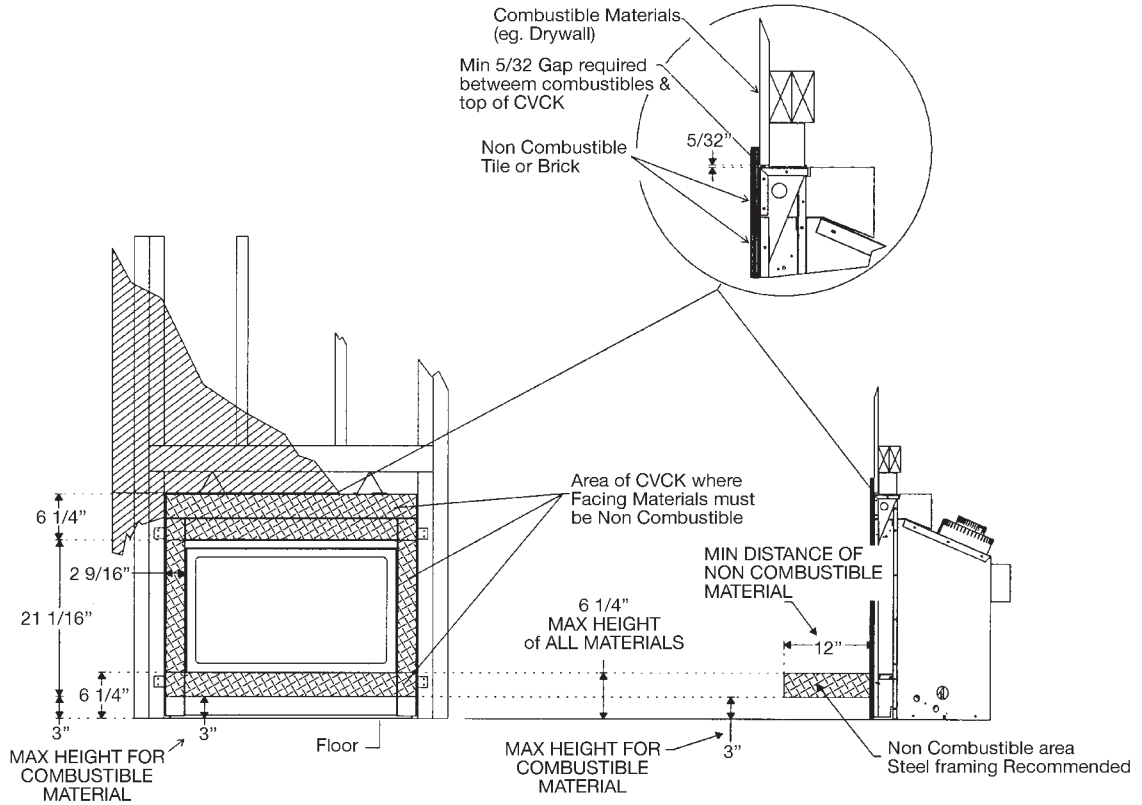

Z33CVCK - with Wall Surround

* Note: A Z33CVCK MUST BE USED WHEN INSTALLING WALL SURROUND *

* Installation of Wall Surround on ZDV3318 fireplace requires the fireplace to be installed at a min height of 2 7/8 from the bottom of fireplace to the finished floor. This will maintain a min air gap of 3/8" from the bottom of Wall Surround to finished floor.

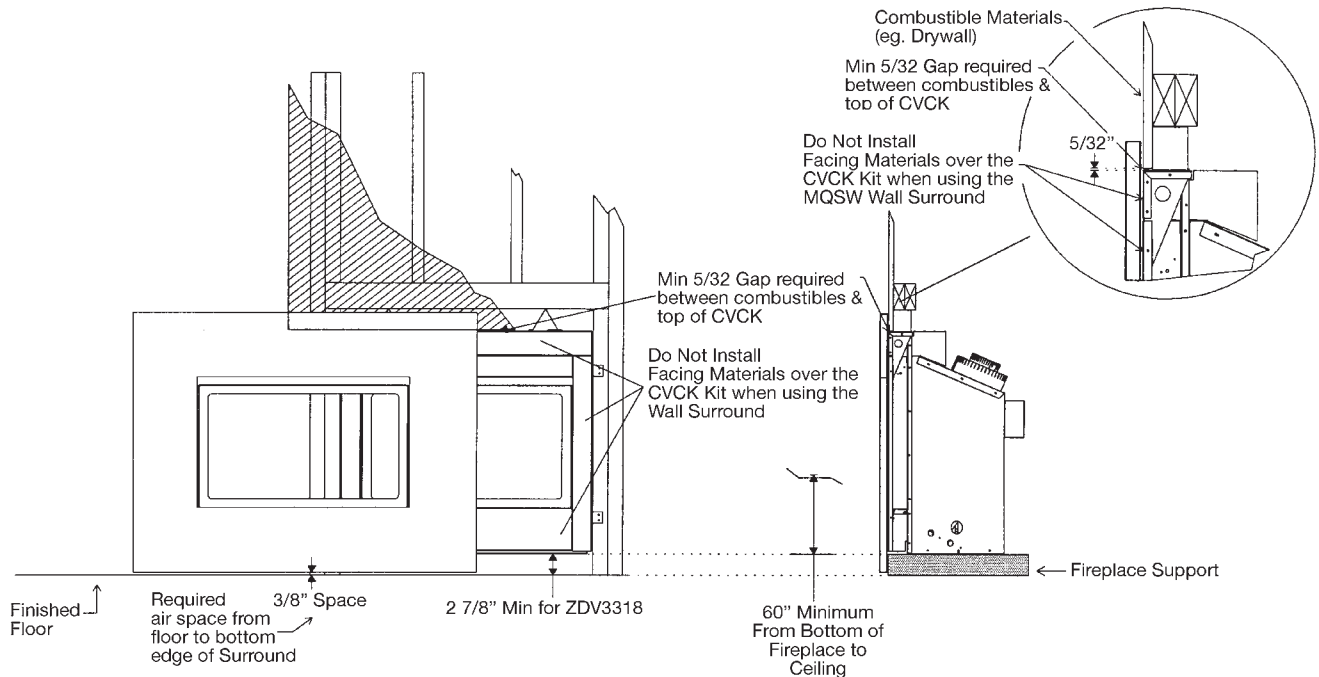

ZDV3622 - Framing for your Gas Fireplace

Framing Specifications

1. Cold climate installation recommendation: When installing this fireplace against non insulated exterior wall or chase, it is recommended that the outer walls be insulated to conform to applicable insulation codes. Drywall must be installed over insulation to prevent contact of insulation and unit.
2. Choose fireplace location and frame in accordance with the fireplace framing dimensions specified (See Framing Diagrams). Bend nailing tabs forward on left and right of unit and place fireplace into framed enclosure. This allows for 1/2" in front of framing tabs for finishing materials.
3. Drywall or other material can extend flush with the appliance on the bottom, sides and top of fireplace. (louvered models only)
4. When installing horizontal with a 90 degree bend maintain a minimum of two and a half (2.5") inches above the bend in enclosures.
5. For a fireplace with louvers combustible floor can raise 1" above the bottom of the fireplace. For a fireplace with 36CVCK (Clean view Circulating Kit) floor or hearth can raise 7" above the bottom of the fireplace with portions being combustible and non combustible. See drawing on following page.
6. When installing MQ36SWF surround, the fireplace must be raised a minimum of 2 1/2" above the finished floors, to accommodate the wall surround. The fireplace may be raised higher but the 60" clearance measured from the bottom of the fireplace to the ceiling must be maintained at all times. (i.e. For an 8 ft. ceiling the unit can be raised only 36 inches.)

It is recommended for **Propane Horizontal Installations** that the venting should be a minimum of one foot vertical off the flue before the elbow on any horizontal runs of one foot or greater. This allows for cleaner combustion and greatly reduces carboning and cleaning of glass.

ZDV3622 Louvered

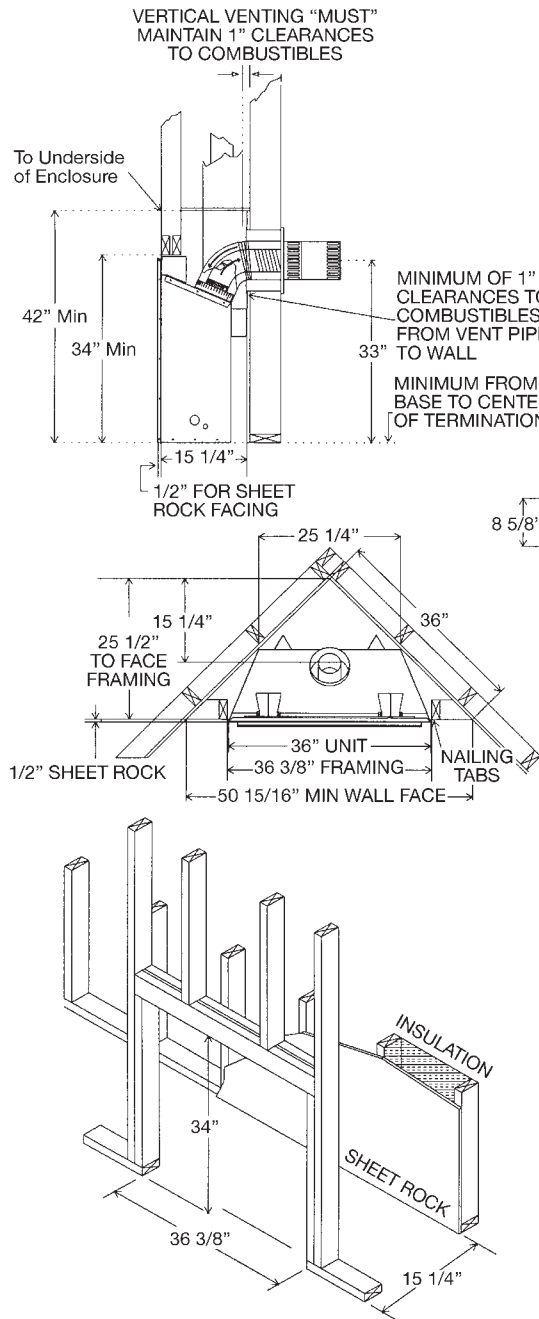

ZDV3622 WITH CVCK (CLEAN VIEW CIRCULATING KIT)

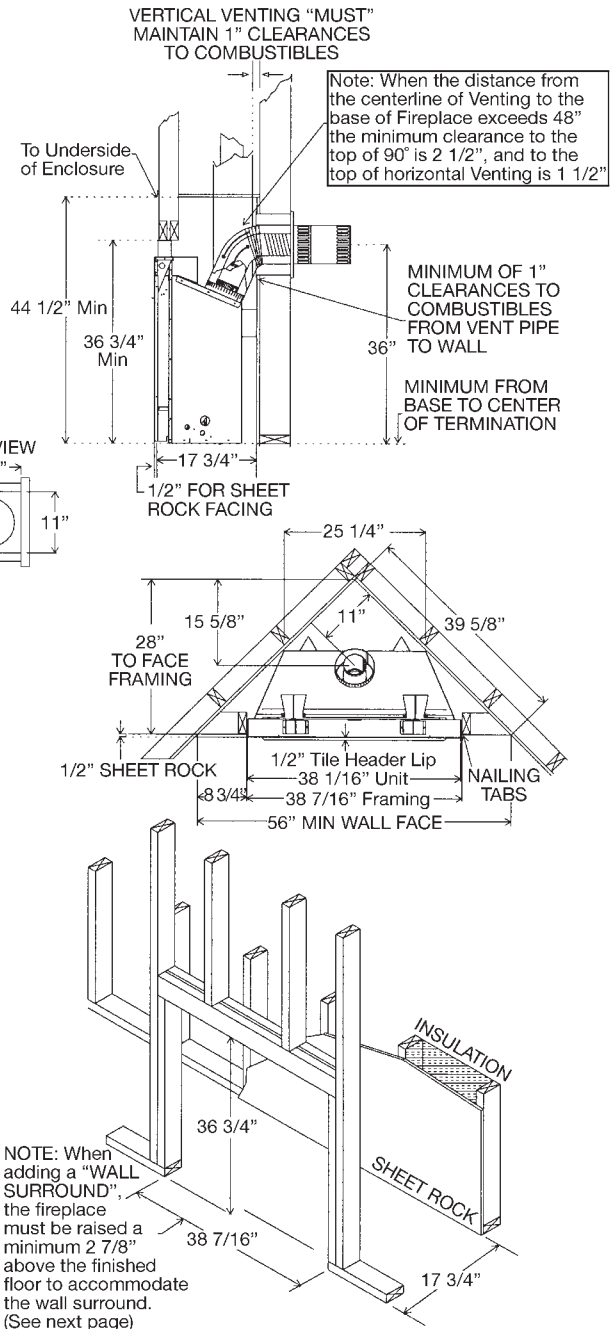

Z36CVCK - Framing and Facing Requirements

ZDV3622 WITH Z36CVCK (CLEAN VIEW CIRCULATING KIT)

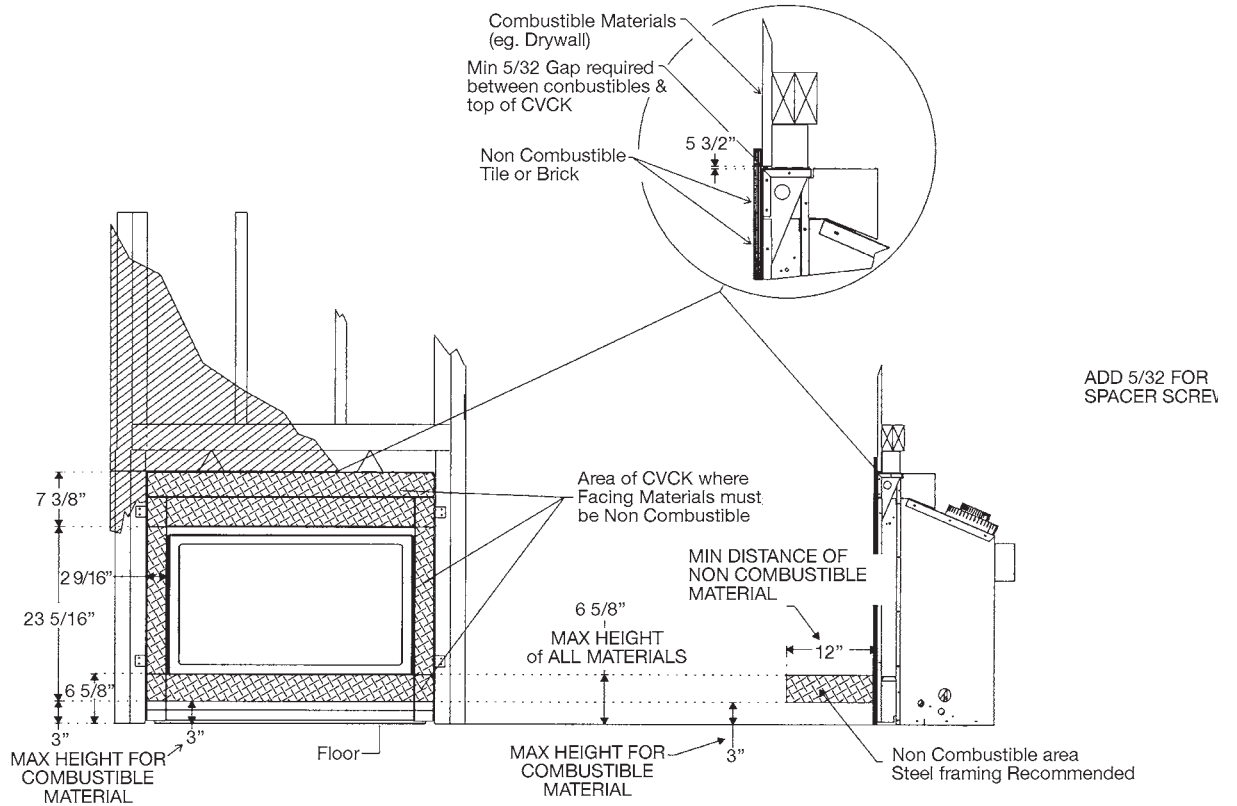

Z36CVCK - with Wall Surround

* Note: A Z36CVCK MUST BE USED WHEN INSTALLING WALL SURROUND *

* Installation of Wall Surround on ZDV3622 fireplace requires the fireplace to be installed at a min height of 2 1/2 from the bottom of fireplace to the finished floor. This will maintain a min air gap of 3/8" from the bottom of Wall Surround to finished floor.

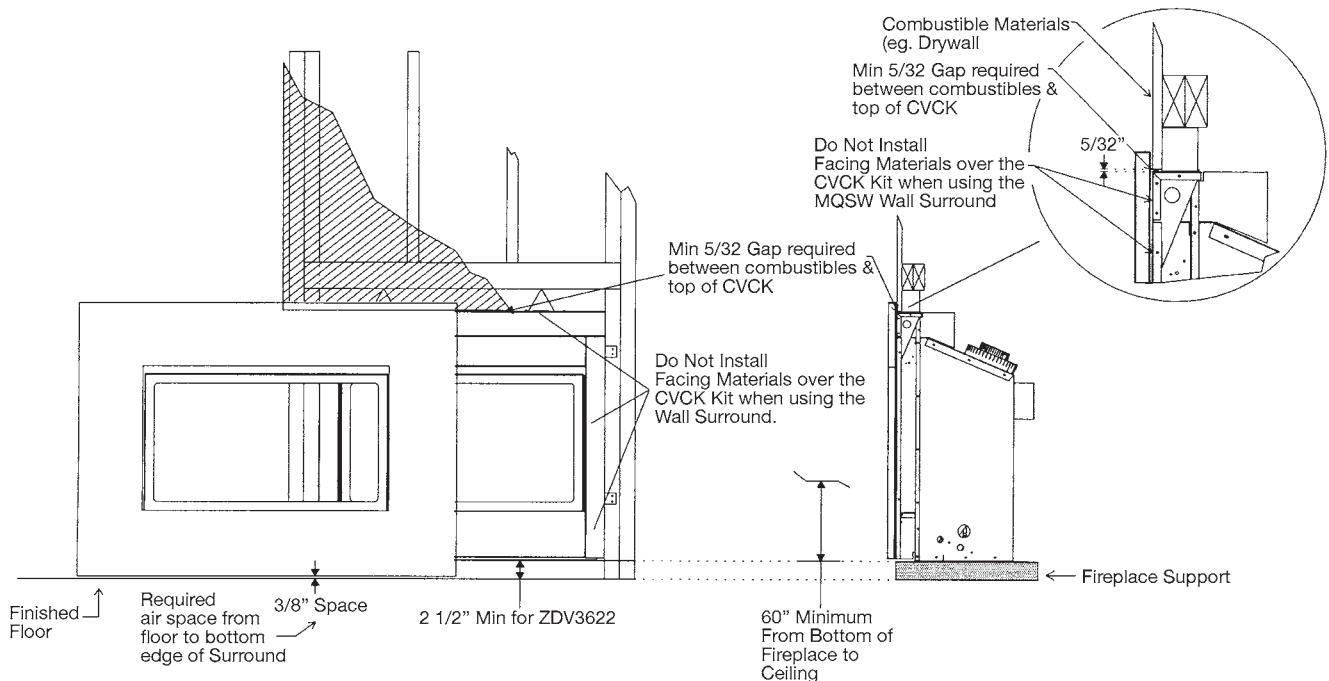

ZDV3318/ZDV3622 - HOW TO INSTALL CLEAN VIEW KIT (CVCK)



Warning: Failure to position the parts in accordance with these diagrams or failure to use only parts specifically approved with this appliance may result in property damage or personal injury.

Installing Clean View Kit (CVCK)

For ZDV3318/ZDV3622/ZDV6000/ZDV3320/MQZDV3318/MQZDV3622

1. Install optional fan kit (See Fan Instructions)
2. (a) All styles except ZDV6000 & ZDV3320. Make sure small standoff is folded up and fastened into position. If not fold standoff up into position and fasten with supplied screws. (Fig 1)
(b) For ZDV6000 & ZDV3320 only. Fold eight inch standoff up into position and install with supplied screws. Do not remove small standoff. The eight inch standoff will fit over the top of the small standoff. (Fig 1)
3. For ZDV6000 & ZDV3320 only. All others skip to Step 4.
Using screws provided, fasten the non-combustible header onto the top of CVCK assembly.
4. Hang CVCK onto top of fireplace retainer tabs and rotate into position. (Fig 2)
5. Using [4] supplied #6 screws, fasten CVCK kit to the inside frame of unit.
Note: Holes are pre-punched into side frame of unit, one hole at the top and one at the bottom.
6. Using [10] supplied screws, install the top heat shield to the top inner side of CVCK. (Fig 3)
Note: It will be easier to install leading edge screws first and side screws last. Some pressure will be required when installing side screws to push top edge up into unit.
7. Kit is supplied with 2 valve extension knob. Align the notches and slide extension knobs onto valve knobs.
8. DO NOT brick or tile beyond the inside area of the CVCK kit to allow for removal of door

NOTE: ADDITIONAL ACCESS FOR GASLINE INSTALLATION AND FAN ELECTRICAL INSTALLATION !
When CVCK is installed in framing, remove the four [4] screws from the bottom panel. Once screws are removed bottom panel can be removed to access gas valve and fan system.

FIG 1

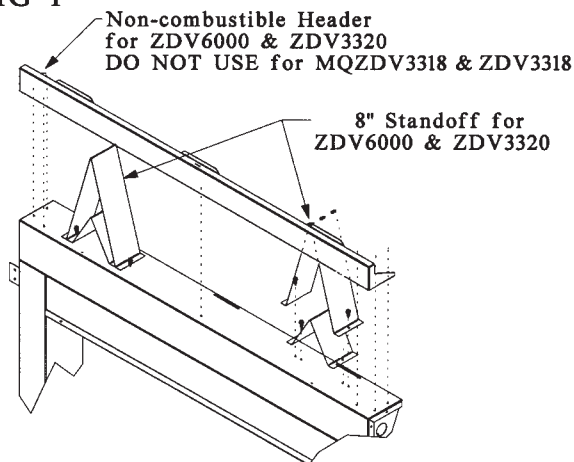
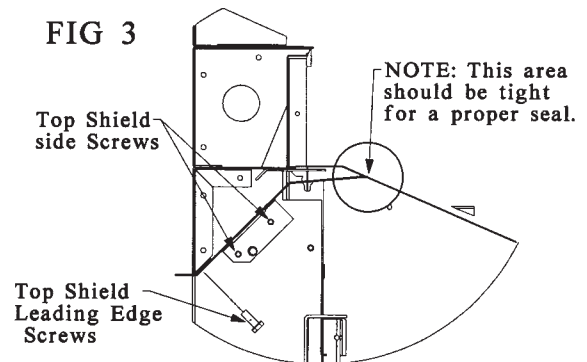

FIG 3



Non-combustible Header for ZDV6000 & ZDV3320
DO NOT USE for MQZDV3318 & ZDV3318

8" Standoff for ZDV6000 & ZDV3320

4 Screws

Top Heat Shield

Retainer Tabs

- CVCK KIT CONTENT**
- 1 x CVCK Metal Surround
 - 20 x 3/8" Screws
 - 4 x #6 Combo Screws
 - 1 x 3" ON/OFF/PILOT Knob
 - 1 x 3" High/Low Knob
 - 1 x Top Shield
 - 1 x Non-combustible Header for 6000/3320 only

Access Cover

Bottom Panel

Retainer Tab Slot

Retainer Tab Slot

FIG 2

CLEARANCES - ZDV3318/3622 - Mantels & Surrounds

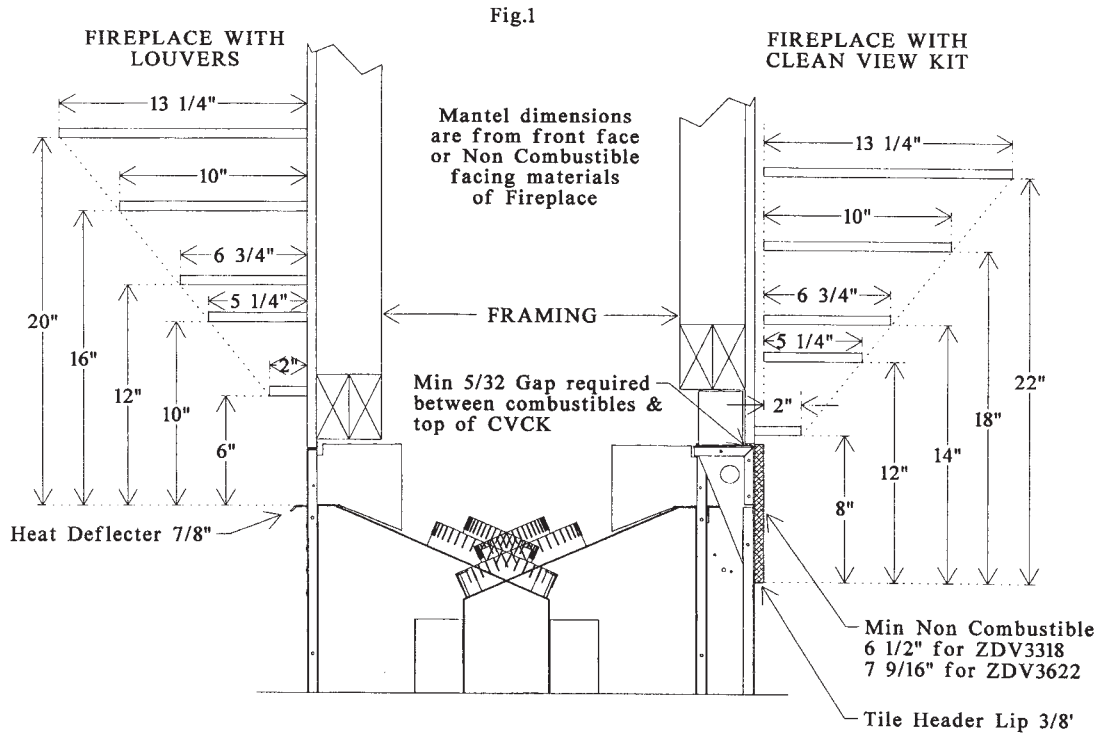

Warning: Combustible objects must not be placed on a non-combustible mantel unless the non-combustible mantel meets the minimum height and width requirements for a combustible mantel.

Fig.2 Fireplace with Clean View Kit and Wall Surround

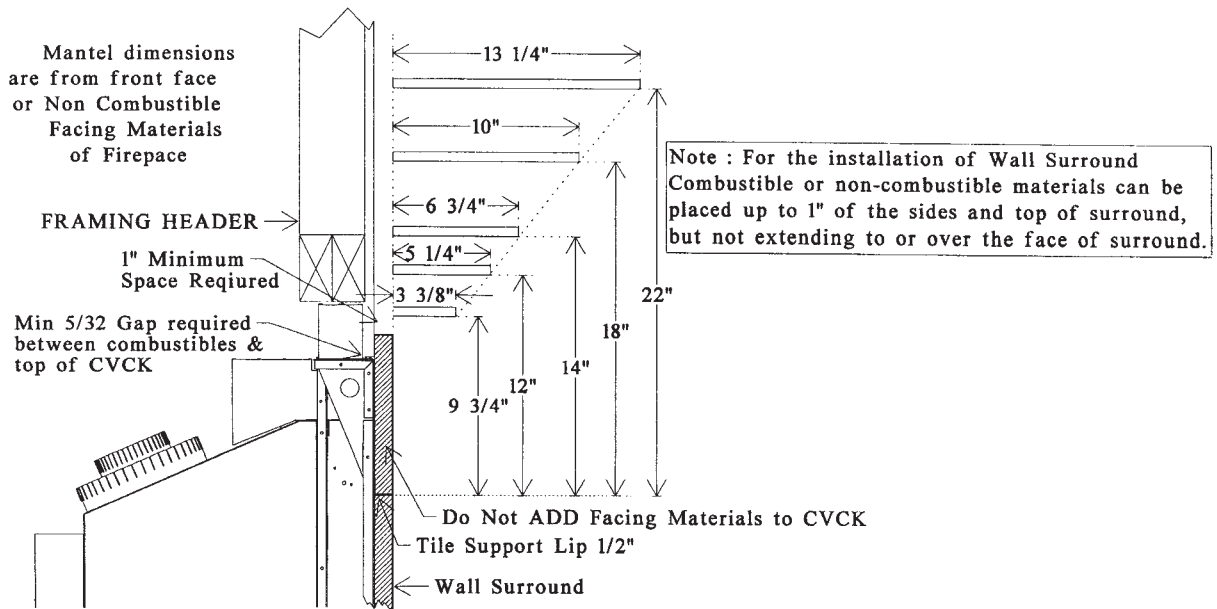

Mantel Leg Clearances

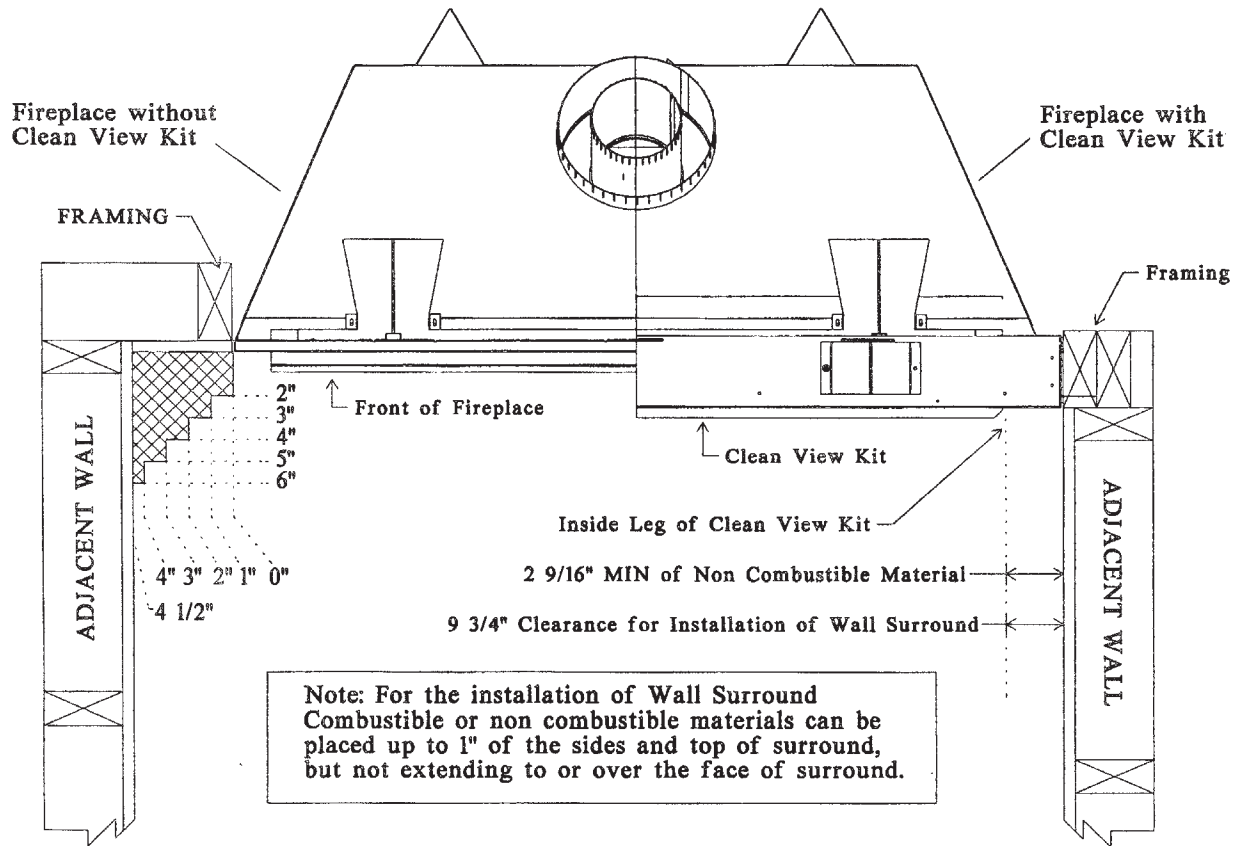

Mantels

Depending on the depth of the fireplace mantel, it may be installed higher or lower from the top of the fireplace opening. See drawings for proper installation height of your combustible mantel. Non-combustible mantels may be installed at any height above the fireplace opening except when using MQHBSW.

Non combustible materials such as brick, tile, etc. can extend up to or over the front face of the fireplace (NO PORTION OF GRILL AREA OR DOOR AREAS CAN BE COVERED) except where designer clean view kit is used.

Combustible material can extend flush to unit up to the top, bottom and sides of fireplace to stand-offs.

For COMBUSTIBLE materials extending in front of fireplace consult (Mantel and Mantel Leg Drawings).

Surrounds

If installing wide or slim line surrounds, the finish materials must be flush with the front facing of the fireplace.

Note: When using paint or lacquer to finish the mantel, such paint or lacquer must be heat resistant (250°F) to prevent discoloration.

ZDV3318 - Clearance to Combustibles

Clearance to Combustibles

Back (from Standoffs)	0 inches/0 mm
Side (from standoffs)	0 inches/0 mm
Floor	0 inches/0 mm
Ceiling (from bottom of fireplace)	60 inches/150 cm
Top (from standoffs)	0 inches/0 mm
Louvered Unit	
Top of 90 degree bend in Minimum Enclosure of 37 3/4 to 40 inches	3 1/4 inches/140 mm / All Vent Systems
Enclosure over 40 inches	2 1/2 inches/38mm/All Vent Systems
CVCK Unit (non louvered)	
Top of 90 degree bend in Minimum Enclosure of 40.5inches to 43 inches	5 inches/38 mm / All Vent Systems
Enclosure over 43inches	2 1/2 inches/38mm All vent Systems
Systems	
Top of Horizontal Pipe	1 1/2 inches/38 mm / All Vent Systems
Side & Bottom of Horizontal Pipe	1 inch/25.5mm / All Vent Systems
Vertical Vent Pipe	1 inch/25.5mm / Kingsman Vent Systems
Vertical Vent Pipe Temp	1 1/4 inch/32mm / Simpson/AmeriVent/Selkirk Direct Systems

(NOTE -Floor) if installing the appliance directly on carpeting or other combustible materials other than wood flooring, the appliance shall be installed on a metal or wood panel, the full width and depth of the appliance. Carpet may extend 1 inch above the floor of appliance.

For units with CVCK (Clear View Circulating Kit) see framing with CVCK to establish floor heights

ZDV3622 - Clearance to Combustibles

Clearance to Combustibles

Back (from Standoffs)	0 inches/0 mm
Side (from standoffs)	0 inches/0 mm
Floor	0 inches/0 mm
Ceiling (from bottom of fireplace)	60 inches/150 cm
Top (from standoffs)	0 inches/0 mm
Louvered Unit	
Top of 90 degree bend in Minimum Enclosure of 42 to 46 inches	5 1/2 inches/140 mm / All Vent Systems
Enclosure over 46 inches	2 1/2 inches/38mm/All Vent Systems
CVCK Unit (non louvered)	
Top of 90 degree bend in Minimum Enclosure of 44.5inches to 48.5 inches	5 inches/38 mm / All Vent Systems
Enclosure over 48.5inches	2 1/2 inches/38mm All vent Systems
Top of Horizontal Pipe	1 1/2 inches/38 mm / All Vent Systems
Side & Bottom of Horizontal Pipe	1 inch/25.5mm / All Vent Systems
Vertical Vent Pipe	1 inch/25.5mm / Kingsman Vent Systems
Vertical Vent Pipe Systems	1 1/4 inch/32mm / Simpson/AmeriVent/Selkirk Direct Temp Systems

(NOTE -Floor) if installing the appliance directly on carpeting or other combustible materials other than wood flooring, the appliance shall be installed on a metal or wood panel, the full width and depth of the appliance. Carpet may extend 1 inch above the floor of appliance.

For units with CVCK (Clear View Circulating Kit) see framing with CVCK to establish floor heights

MQSW Wall Mount Surround Dimensions

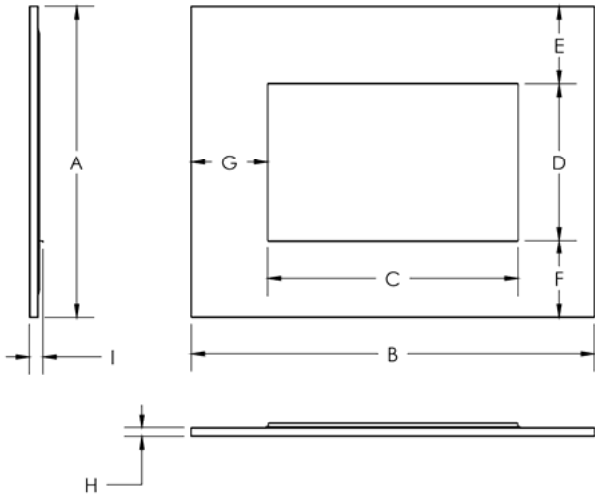

	MQ33SWF	MQ36SWF
A	35-5/16"	37-5/32"
B	45-13/16"	50-5/16"
C	28-3/8"	32-15/16"
D	17-13/16"	19-5/8"
E	8-3/4"	8-3/4"
F	8-3/4"	8-3/4"
G	8-3/4"	8-3/4"
H	1"	1"
I	1-3/16"	1-3/16"

Installation of MQ Wall Mount Surrounds

Parts List

- Modern Surround
- 2x Mounting Screws

Tools Required

- Phillips Head Screwdriver

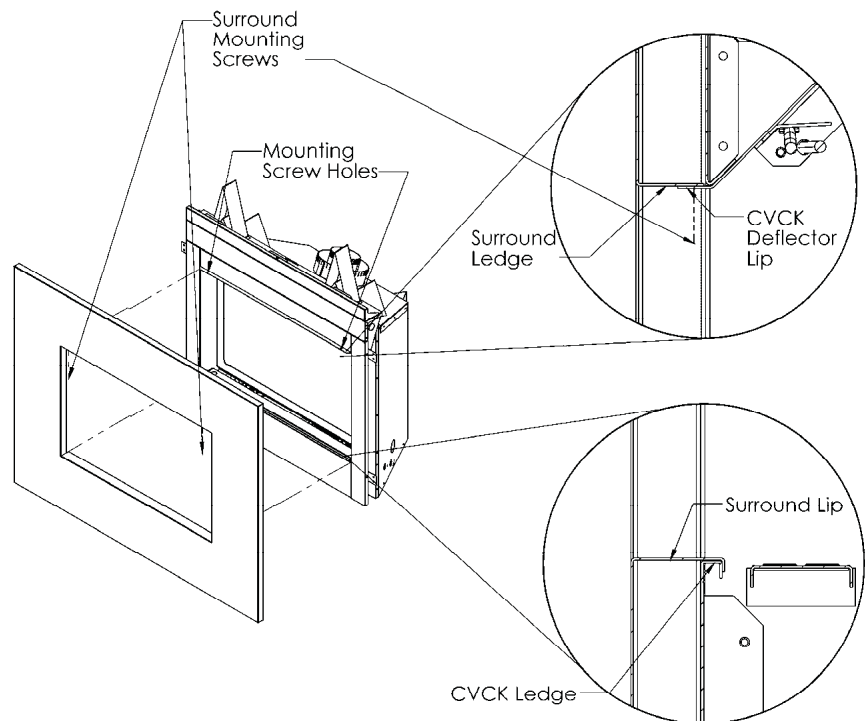

1. Set Surround Lip on CVCK Ledge and ensure that it is securely in place.
2. Swing the upper portion of the Surround so that the Surround Ledge is resting on top of the CVCK Deflector Lip.
3. Align the Mounting Screw Holes and fasten the Surround in place with the supplied screws.
4. Attach optional decorative bands as desire.
5. To remove, simply reverse these steps.

Fan Kit Installation

Fan installation Instructions for ZDV6000/3320/3318/3318MQ with or without CVCK (Clean View Circulating Kit).

Note: Install Fan Kit Before Installing optional CVCK (Clean View Circulating Kit).

If CVCK has been installed into framing additional access is provided by removing screws from bottom panel of CVCK. See **Installing Clean View Kit (CVCK)**.

- Slide fan housing into unit and place over 2 Fan Retainer Tabs. Tabs are pre punched and bent up (***Note: on 6000/3320 units, these Tabs are located on the right side of the unit**). Rubber grommets at the base of the fan should fit snugly over the tabs.
- For Fan Disc Installation these units have been installed with a sliding track system. Install the Thermodisc provided with the Fan Kit. Place Thermodisc into sliding assembly (**Fig.1**), and attach 2 leads exiting right side of the fan housing into thermodisc. Now slide disc assembly into thermodisc track (**Fig.2**). Place swivel handle of disc assembly on track to lock into position. To service disc simply pull swivel handle slide towards you while rotating handle to access disc.

Caution: Label all wires prior to disconnection when servicing controls. Wiring errors can cause improper and dangerous operation. Verify proper operation after servicing.

Parts List:

- 1ea. Fan comes with 4ft cord. Two 14" leads (female ends)
- 1ea. Variable speed control (wall mount type)
- 1ea. Thermodisc
- 1 Thermodisc mount assembly

- Wire Junction Box and wall mounted variable speed control to 120v. Install a duplex outlet to junction box and plug fan into outlet.
- Turn the wall switch on (clockwise). Turn fireplace on. Once the sensor in the unit reaches operating temperature (approximately 10 to 15 minutes) the fan will turn on. The fan can be switched off if desired by turning the wall switch fully counter clockwise.
- To set the minimum fan speed, remove the variable switch from the wall mount. Turn the variable speed wall controller to its minimum setting (fully counterclockwise). Use the set screw on the side of the variable speed controller to increase or decrease the minimum fan speed (lowering the minimum fan speed will decrease sound level created by fan). Reinstall switch into wall mount and cover with face plate.

Note: To service fan with CVCK Kit installed see Removing Burner System in manual. If CVCK is finished with a MQSW Wall Surround the MQSW may be removed by removing the 4 attachment screws and removing the MQSW allowing access into the bottom of the fireplace to service blower.

Electrical Services

All optional Fan Kits are equipped with a 120V, 60Hz, .4amp blower. Note: All electric connections are to be made in accordance with CSA Standard C22.1 – Canadian Electrical Code part 1 or with the National Electrical Code, ANSI/NFPA 70 (latest edition) and /or in accordance with local codes.



WARNING: Electrical Grounding Instructions.
This appliance is equipped with a three-pronged (grounding) plug for your protection against shock hazard and should be plugged directly into a properly grounded three-prong receptacle. Do not cut or remove the grounding prong from this plug.

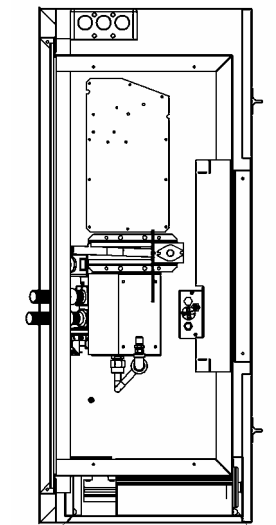
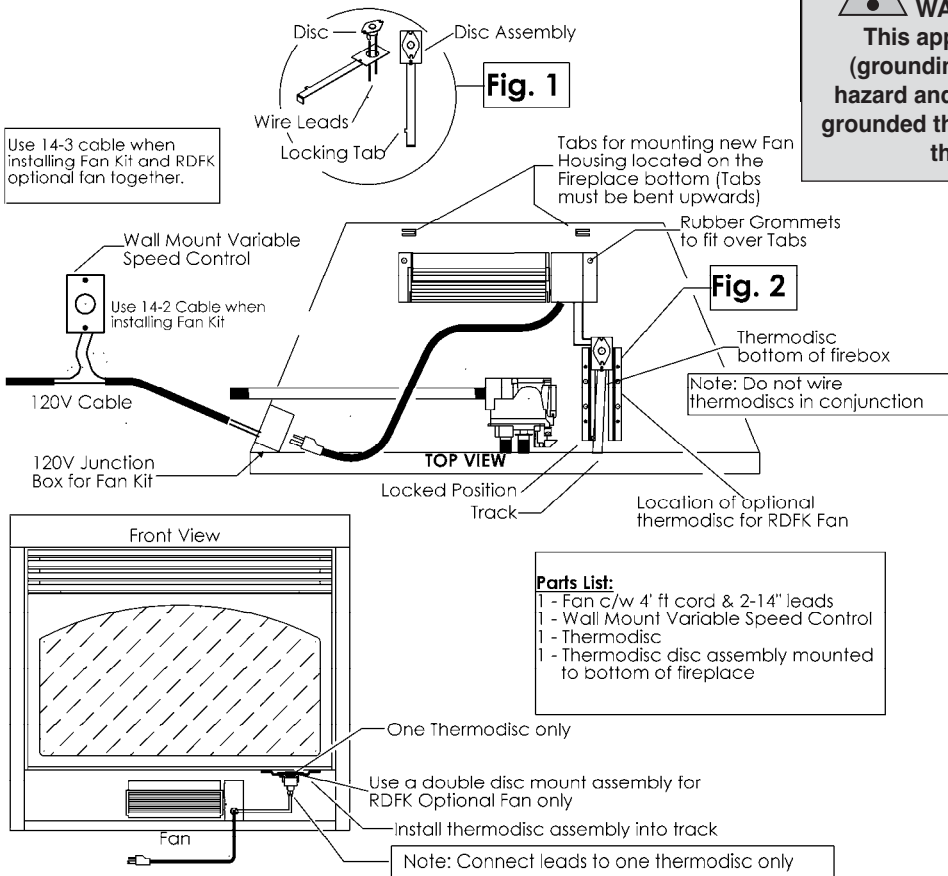

CAUTION: DO NOT ATTACH 120V FAN ASSEMBLY TO MILLIVOLT GAS VALVE SYSTEM

Brick Installation - For Models ZDV3318/ZDV3622

1. Remove 3 mounting screws from air adjustment plate and remove plate.
 On ZDV3318 or ZDV3622 the false bottom will have to be removed.
 (Note: Air adjustment plate must be reinstalled in the same position in which it was removed.)
2. Remove top brick clip and screws from firebox side. Screws will be reused for the installation of side Liner Panels. (Fig. 1)
3. Remove four side screws from the firebox bottom. There are two screws per side. Screws will be reused for the installation of side Liner Panels. (Fig. 1)
4. Place rear Liner Panel against back of firebox. When placing Panel tilt panel towards you and lift panel over the burner assembly. (Fig. 2)
5. To place side Liner Panels rotate panel towards you and place bottom edge of panel over the front ledge of firebox. (Fig. 3) Rotate panel upright and slide back up to face of rear Liner Panel. Make sure top of side Liner Panel is engaged with top of rear Liner Panel. (Fig 4 - Detail: A) To finish the installation fasten bottom of side Liner Panel with screws removed in step 3 and fasten top of side Liner Panel with screws removed in step 2.
6. Using screws removed in step 1 reinstall air adjustment plate and false bottom.
 (Note: If air adjustment plate was required to be installed in the up position it is not required to reinstall the air adjustment plate. Not installing the air adjustment plate will leave mor of the rear Liner Panel exposed for a more finished appearance.)

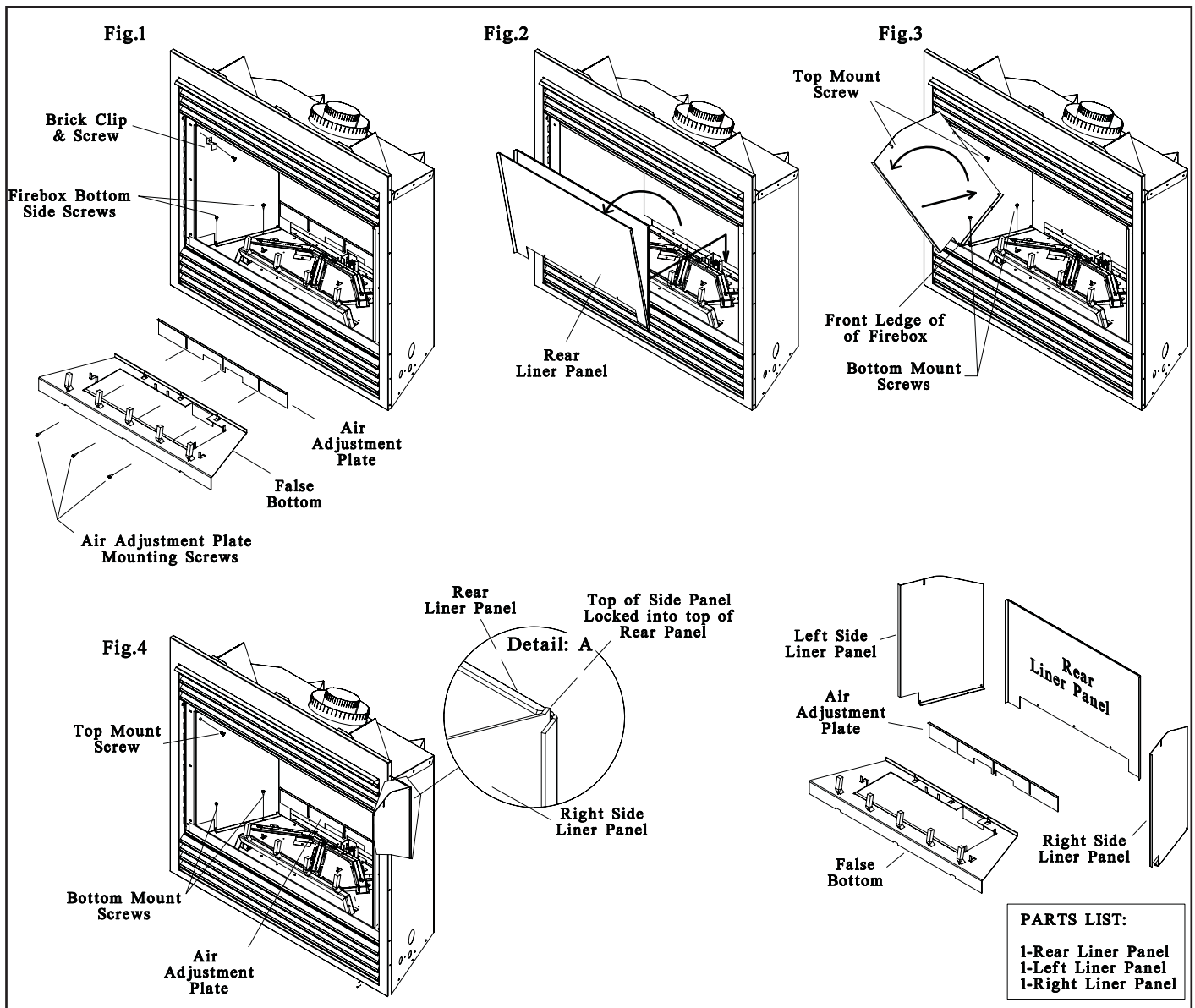

Z3318PRL/Z3622PRL Porcelain Panel Installation Guide

For Models ZDV3318/ZDV3622
MQZDV3318/MQZDV3622

1. Make note of the position of the air adjustment plate before removing it. This position will have to be recalled when the air adjustment plate is reinstalled.
2. Remove three (3) mounting screws from air adjustment plate and extract it from the firebox. (NOTE: The false bottom will have to be removed on models ZDV3318 and ZDV3622.)
3. Remove the top brick clips, and their respective screws, from the inside sides of the firebox. These removed screws will be reused for installation of the side liner panels.
4. Place the rear liner panel against the back of the firebox. When placing the panel, tilt it towards you while lifting it over the burner assembly,
5. To place the side liner panels, rotate it towards you while placing the bottom edge over the front ledge of the firebox. Then, rotate the panel upright and slide it back towards the rear liner panel. Make sure the top of the side panel is engaged with the top of the rear panel as shown in the illustration below. Once all the liner panels are installed, ensure they are sitting flush to the walls of the firebox.
6. Reinstall the air adjustment plate back to its original position. (NOTE: Only for instances where the adjustment plate is in the extreme up position, it is not necessary to reinstall the plate. One may prefer not to install the plate for a more finished appearance.)
7. If applicable, reinstall the false bottom.

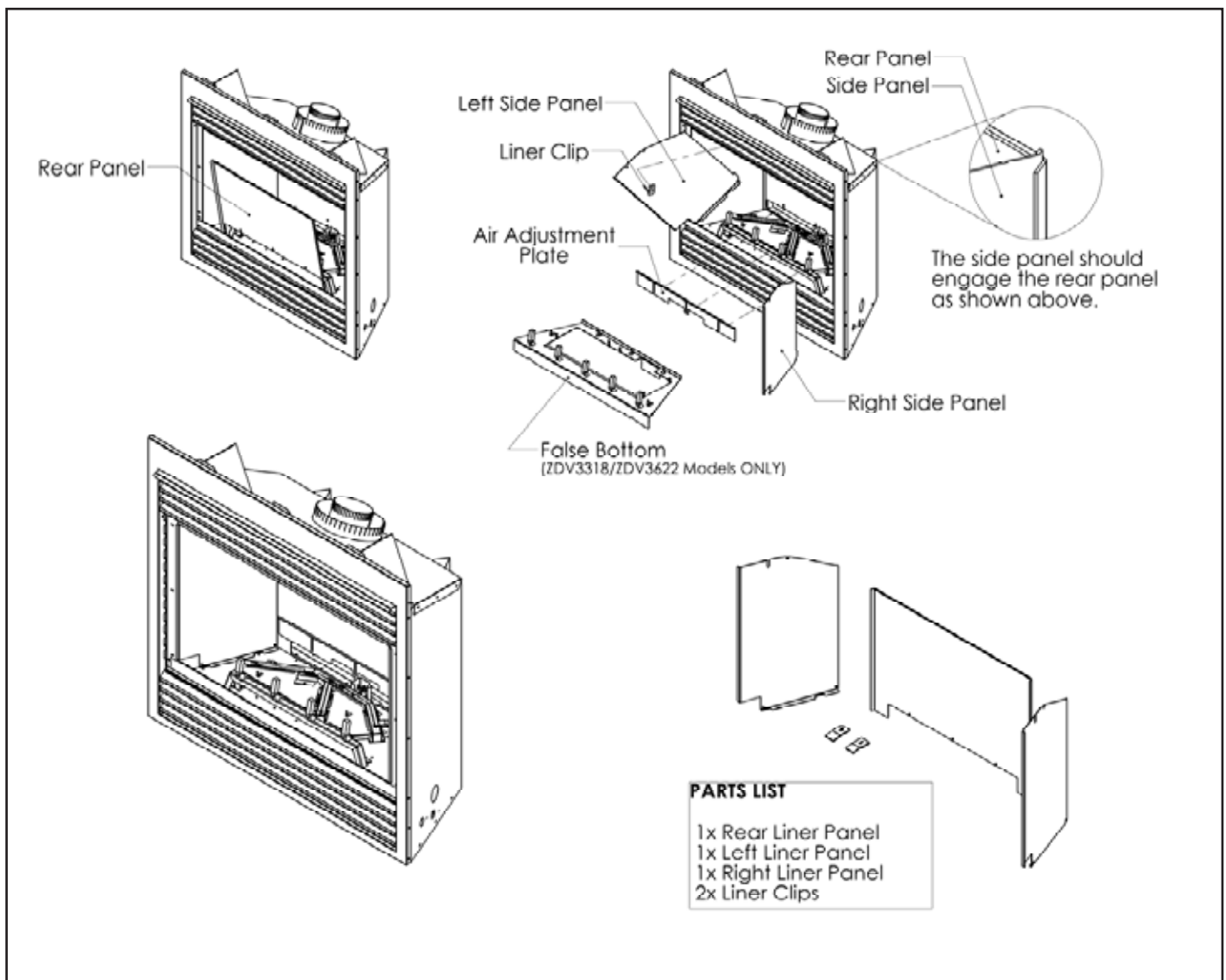

General Glass Information

Glass Cleaning

It will be necessary to clean the glass periodically. During start-up, condensation, which is normal, forms on the inside of the glass and causes dust, lint etc. to cling to the glass surface. Also, initial paint curing can deposit a slight film on the glass. It is therefore recommended that initially the glass be cleaned two or three times with **non-abrasive** common household glass cleansers and warm water. After that, the glass should be cleaned two or three times a season depending on the circumstances.



Warning and Cautions.

- Do not clean when the glass is hot.
- Do not use abrasive cleaners.
- Using a substitute glass will void all product warranties.
- Do not strike or abuse glass. Care must be taken to avoid breakage of the glass.
- Do not operate this fireplace without the glass front or with a broken glass.

Glass Replacement

The glass should be replaced by a qualified person.

REPLACEMENT GLASS FOR BOTH DIRECT VENT UNITS

These models can use either tempered glass or Robax ceramic or coated Neoceram glass. Must be 5mm thick.

To replace glass, clean all materials from door frame. Scrape off old silicone down to metal. Using a high heat silicone (temperature-resistant to 500°F (260°C)) apply a continuous bead of approximately 1/32" to all four sides of frame and insert glass with new gasket. Frame should be on flat surface, with a small amount of weight pressing glass into silicone. Let dry approximately 15 to 20 minutes. The door can be re-installed by reversing Steps 1 & 2. Use caution when removing broken glass, wear gloves.

Removal of the Glass Door

1. Unlatch the two latches located behind the upper grill.
2. To remove, pull frame forward and lift from bottom door retainer.

Gas Line Installation

This gas appliance should be installed by a qualified installer in accordance with local building codes and with current CAN/CGA - B149.1 or .2 installation codes for Gas Burning appliances and equipment in Canada and the National Fuel Gas Code ANSI Z223 in the U.S.A.

1. The gas pipeline can be brought in through either the right or the left side of the appliance. A knockout is provided at either location to allow for the gas pipe installation and testing of any gas connection.
2. The gas control inlet is 3/8" NPT. Typical installation layout for rigid pipe is shown at right.
3. When using **copper** or **flex connector**, use only approved fittings. Always provide a union so that gas line can be easily disconnected for burner or fan servicing. See gas specification for pressure details and ratings.
4. When a vertical section of gas pipe is required for the installation, a condensation trap is needed. See CAN/CGA-B149.1 or .2 for code details.
5. For natural gas, a minimum of 3/8" iron pipe with gas minimum pressure of 4.5" w.c. must be used for supply from the gas meter. Consult with the local gas utility if any questions arise concerning pipe sizes.
6. A 1/8" NPT plugged tappings are accessible for test gauge connection both on the inlet and outlet of the gas valve.
7. Turn the gas supply ON and check for leaks. **DO NOT USE OPEN FLAME FOR THIS PURPOSE.** Use an approved leak testing solution.
8. The appliance and its individual shutoff valve must be disconnected from the gas supply piping system during any pressure testing of that system at test pressures in excess of 1/2 PSIG (3.5 KPa).
9. The appliance must be isolated from the gas supply piping system by closing its individual shutoff valve during any pressure testing of the gas supply piping system at test pressures equal to or less than 1/2 PSIG (3.5 KPa).

Note: The gas line connection may be made of 1/2" rigid pipe or an approved flex connector. Since some municipalities have additional local codes, it is always best to consult your local authorities and the current CAN/CGA - B149.1 or .2 installation code in Canada or the National Fuel Gas code ANSI Z223.1 in the U.S.A.

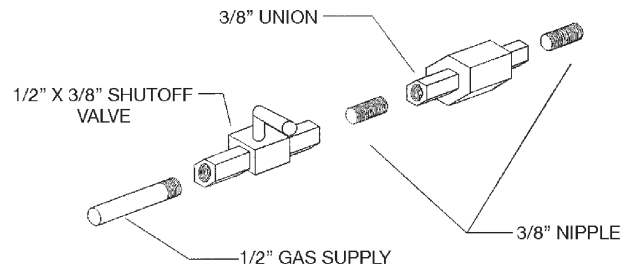

Important: Always check for gas leaks with a soap and water solution. Do not use open flame for leak testing.

Gas Specifications

Models	ZDV3318N	ZDV3318LP	ZDV3622N	ZDV3622LP
Fuel	Natural	Propane	Natural	Propane
Gas Control	Millivolt adjustable	Millivolt adjustable	Millivolt adjustable	Millivolt adjustable
Input Maximum	19,000 BTU	18,000 BTU	21,000 BTU	21,000 BTU
Low	12,100 BTU Low	11,900 BTU	14,200 BTU	16,200 BTU
Orifice Size (0 - 4500 ft)	#45	#55	#43	#54
Air Shutter	3/16" Open	9/32" Open	3/16" Open	3/8" Open
Gas Inlet Size	S.I.T. 820 Nova, 3/8" NPT			
Gas Supply Pressure	Minimum	Normal	Maximum	
Natural Gas	5.5"	7"	9"	
Liquid Propane	11"	11"	12"	
Manifold Pressure	Natural Gas			Liquid Propane
Manifold Pressure High	3.5 IN. W.C./1.87 KPa			10 IN. W.C./2.61 KPa
Manifold Pressure Low	1.6 IN. W.C./1.40 KPa			6.3 IN. W.C./1.57 KPa

For the state of Massachusetts a **T-handle gas shut-off valve** must be used on a gas appliance. This T-handle gas shut-off valve must be listed and approved by the state of Massachusetts. This is in reference to the state of Massachusetts state code CMR238.

Millivolt System, Lighting, & Burner Control

FOR YOUR SAFETY READ BEFORE LIGHTING

WARNING: If you do not follow these instructions exactly, a fire or explosion may result causing property damage, personal injury or loss of life.

BEFORE LIGHTING



- A** This appliance has a pilot which must be lighted by hand. When lighting the pilot, follow these instructions exactly.
- B** Smell all around the appliance area for gas. Be sure to smell next to the floor because some gas is heavier than air and will settle on the floor.

WHAT TO DO IF YOU SMELL GAS

- Do not try to light an appliance.
- Do not touch any electrical switch; do not use any phone in your building.
- Immediately call your gas supplier from a neighbour's phone. Follow the gas supplier's instructions.

- If you cannot reach your gas supplier, call the fire department.
- C** Use only your hand to push or turn the gas control knob. Never use tools. If the knob will not push in or turn by hand, don't try to repair it, call a qualified technician. Force or attempted repair may result in a fire or explosion.
- D** Do not use this appliance if any part has been under water. Immediately call a qualified service technician to inspect the appliance and to replace any part of the control system which has been under water.

LIGHTING INSTRUCTIONS

1. Stop! Read the safety information above on this label.
2. Set the thermostat to lowest setting.
3. Turn off all electrical power to the appliance.
4. Locate valve under the burner assembly.
5. If the control knob is not already in the off position, ie. the word "OFF" in the 9 o'clock position, then push in the gas control knob slightly and turn  clockwise to "OFF".
NOTE: Knob cannot be turned from "PILOT" to "OFF" unless knob is pushed in slightly. Do not use force.
6. Wait five (5) minutes to clear out any gas. If you then smell gas. STOP! Follow "B" in the safety information above on this label. If you don't smell gas then go to the next step.
7. Now push in the control knob slightly and turn counter-clockwise  to the "PILOT" position.

8. Push in the control knob all the way and hold it. With the other hand push in the red ignitor button until you hear a click. Now observe closely the pilot burner located on the rear center-left hand side of the main burner. If a flame has appeared then continue to depress the control knob for 20 seconds. If the flame did not appear then continue to depress the red ignitor button every 5 seconds until a flame is established. NOTE: If after 30 seconds a flame has not yet been established then turn the control knob back to the off position and repeat steps 5, 6 & 7.
9. Once the pilot has been established hold the control knob in the depressed position for approximately 25 seconds before releasing. If the flame goes out then repeat steps 7 and 8.
10. Now turn the control knob to the "ON" position. The burner will not light unless the wall switch thermostat or remote control is turned "ON" or in the case of the thermostat there is a call for heat.
11. Close the access door and turn all electric power back to the appliance.

TO TURN OFF THE APPLIANCE

1. Set the thermostat to lowest setting.
2. Turn off all electric power to the appliance if service is to be performed.
3. Open the control access door.

4. Push in the gas control knob slightly and turn clockwise  to the "OFF" position. Do not force.
5. Replace control access panel.

Recommended Maximum Lead Length (Double Wire) When Using Wall Switch or Thermostat

Wire Size	Max. Length
14 GA.	100 FT.
16 GA.	64 FT.
18 GA.	40 FT.
20 GA.	25 FT.
22 GA.	16 FT.

Pilot Burner Adjustment

1. Adjust pilot screw to provide proper sized flame.

Caution: Do Not Wire 120 Volt Power To Millivolt Switches Or Thermostats.

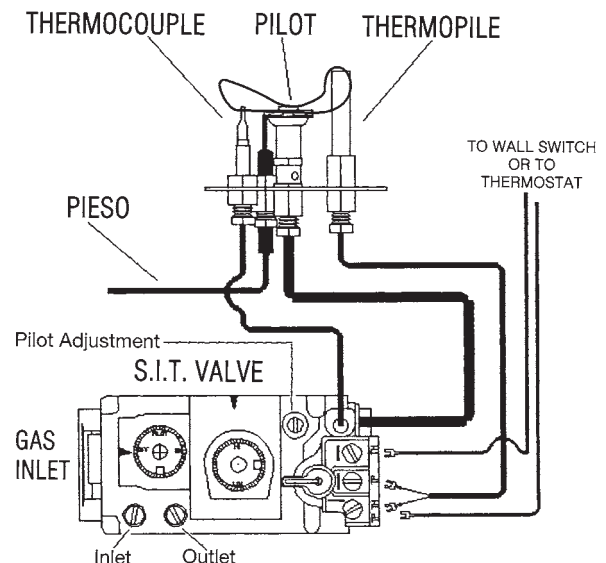

Section B - Installation Instructions

Gas Conversion Kit for Top Convertible Pilot - Series 091065X

Instructions for converting SIT 190 series pilot burner injection from NG to LPG and from NG to LPG Only. This information should be considered as supplemental to the Appliance Manufacturer's Instructions.



WARNING!

The installation of this conversion kit must only be undertaken by a qualified and certified gas appliance installer.

- 1 Shut off the gas supply to the appliance.
- 2 Allow the pilot burner to cool to room temperature.
WARNING: Touching a hot pilot burner can result in injury.
- 3 The pilot hood is held in place by spring pressure. Remove the hood by pulling it directly up from the pilot bracket (1).
- 4 Insert a 5/32" or 4mm Allen wrench into the hexagonal key-way of the injector (2), and rotate it counter clockwise until it is free of the injector journal (3).
- 5 Verify that the new injector is proper for the application. The injector size is stamped on the side of the injector near the top. LPG injectors have a groove machined around their circumference near the top, while NG injectors do not have a groove (5). Refer to the Appliance Manufacturers instruction sheet for the proper injector size.
- 6 Insert the Allen wrench into the end of the injector. Then, insert into injector journal, and rotate the injector clockwise until a torque of 9 in-lbs. is achieved.
- 7 Replace the pilot hood by aligning the tab on the base of the hood with the slot in the side of the pilot journal, and push the hood down, directly onto the pilot bracket (4). The hood must sit squarely on the bracket for proper operation. Check to insure that the hood is properly seated onto the pilot bracket.

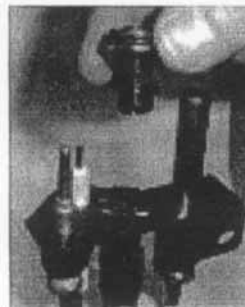

Fig. 1



Fig. 2



Fig. 3

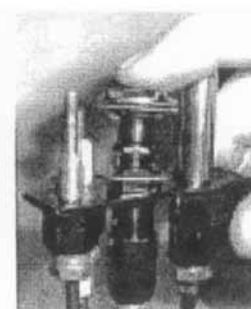

Fig. 4

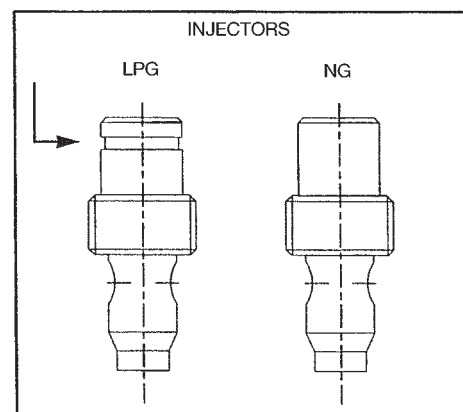

Fig. 5

WARNING!

This conversion kit must only be applied as part of a conversion kit supplied by the appliance Manufacturer for the specific appliance, and type of gas being converted.

INSTALLER NOTICE. These instructions must be left with appliance.

IPI Electronic Ignition System

Overview

The IPI system is an advanced burner controller that provides you with the option of having either a Standing-Pilot, or an intermittent igniting system. This alternating mode is controlled by the CPI/IPI Switch (Continuous Pilot Ignition/Intermittent Pilot Ignition) located on the IPI System Box. The difference between a Standing-Pilot and an Intermittent-Pilot is in whether the pilot stays lit or shuts off:

In Standing-Pilot, the pilot assembly is lit by the IPI Main Module and continues to stay lit until 1) the CPI/IPI Switch is switched to the IPI position; 2) a loss of electrical power (battery and AC source), 3) the flame sensor loses its signal, 4) the fuel supply discontinues, or 5) the IPI Main Module malfunctions.

In the Intermittent-Pilot mode, the pilot shuts off when the appliance is not in use. The advantage of this mode is that fuel is not consumed when the fireplace is not operating.

NOTE: In some jurisdiction, Intermittent-Pilot is required. That means the pilot cannot remain lit when the appliance is not operating.

Components

The core of the IPI system is the Main Module and the IPI Valve. With these two components the system is able to operate a gas fireplace. There are also other components available to complement the IPI system.

IPI System Cover: Is essential in keeping the components at their proper operating temperatures. **DO NOT OPERATE THE APPLIANCE WITHOUT THIS COVER.**

Modulating Servo Motor: Is an add-on valve component that permits HI/LO functionality to be controlled by the remote. Contrary to this feature is a Manual HI/LO Control Knob. The Modulating Servo Motor requires the Remote system to be present.

Backup Battery Pack: This component permits the IPI system to operate without the need for an external AC Adapter power source. The advantage to using the battery backup is that in the case of a power failure, the appliance is still

NOTE: In certain instances the IPI Main Module requires resetting. This can occur if the system is unable to ignite the pilot or the main burner in the allotted time period. The IPI is programmed to lockout all commands. To reset this lockout you must deplete the system of all electrical power. This means to remove the batteries from the Battery Pack, remove the batteries from the Remote Receiver (if applicable), and disconnect the AC Adapter from the system. Leave the power off for approximately 25 seconds to clear its lockout.

operable.

Remote Receiver: This component provides the capability of controlling the appliance with a wireless remote transmitter. There are two switches to note on the receiver module:

The first switch on the Remote Receiver module is a 3-position slide switch. This switch is used to either manually turn the main burner ON, activate the receiver to begin communication with the transmitter, or turn the main burner completely OFF. The position of the slide switch designates these functions respectively.

The second is the small round pushbutton [PRG] used for programming the receiver to respond to a designated remote. Therefore to program the system ensure that the transmitter is first turned OFF. Then, ensure that there is sufficient electrical power going to the Receiver module and a fresh set of batteries in the transmitter. Now switch the

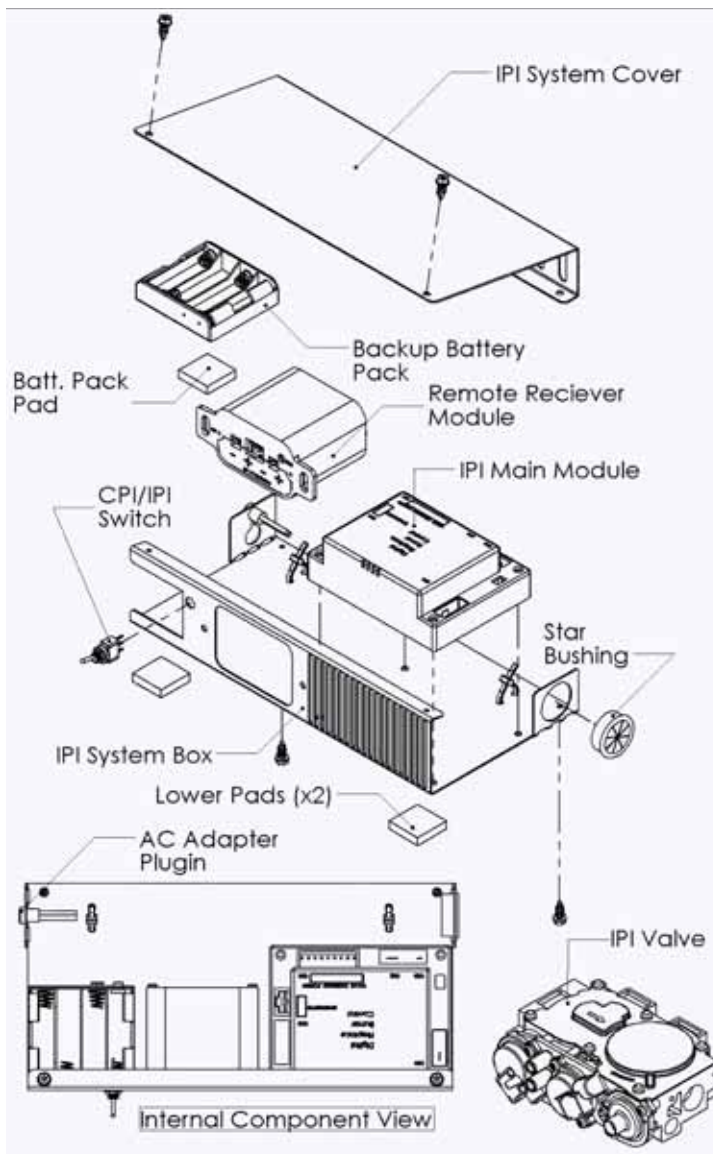

the slide switch to the middle [REMOTE] position and then push the small pushbutton to begin programming. Bring the transmitter close to the receiver and then press the power button [R] on the transmitter. An audible beep will sound to indicate the system is programmed and ready to be used.

NOTE: The Remote Receiver module can also be located outside of the appliance to a maximum of 6ft away installed in a certified deep wall switch electrical box (2-3/4" depth). For this configuration an extension wiring harness (P/N: 1001-P904SI) is required.

Electrical Supply in Series: The entire IPI system can be powered by a single power source (i.e. by the AC Adapter). This is advantageous if you do not want to supply extra batteries. To achieve this simply connect the AC Adapter into the Remote Control wiring harness instead of the main IPI harness. From the Remote wiring harness, use its male plug-in connector and connect it to the female plug-in in the main IPI harness. Now the circuit is complete. So the way it works is that electrical power is supplied to the Remote Receiver module and then proceeds to the Main IPI module. Furthermore, note that a Backup Battery Pack is not required in this configuration. Instead, batteries in the Remote Receiver act as the backup supply.

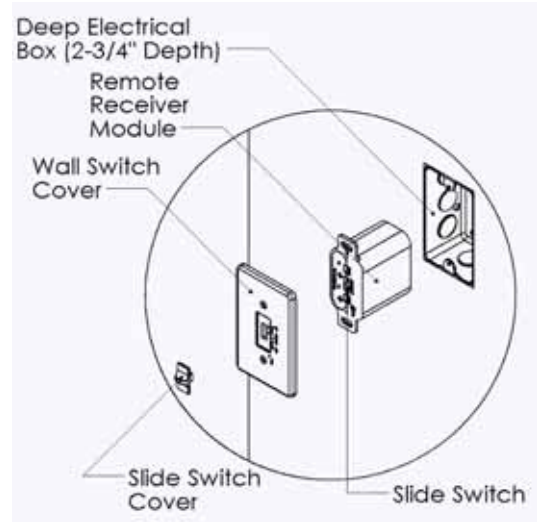

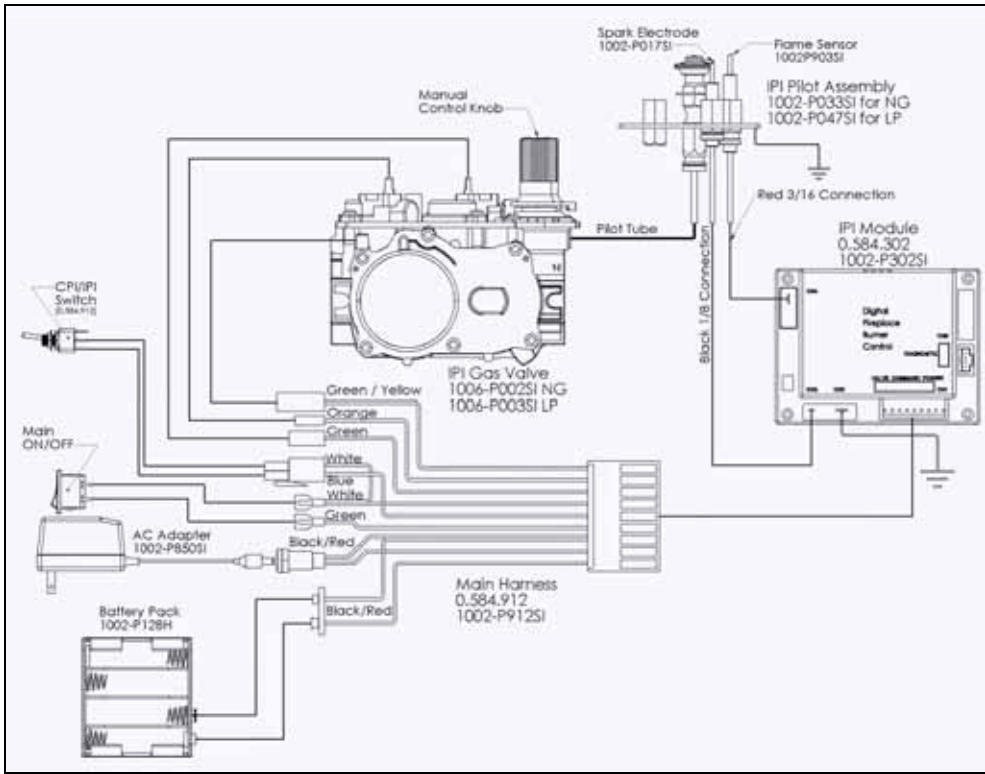

Configuration #1: Basic manual HI/LO and manual ON/OFF capabilities.

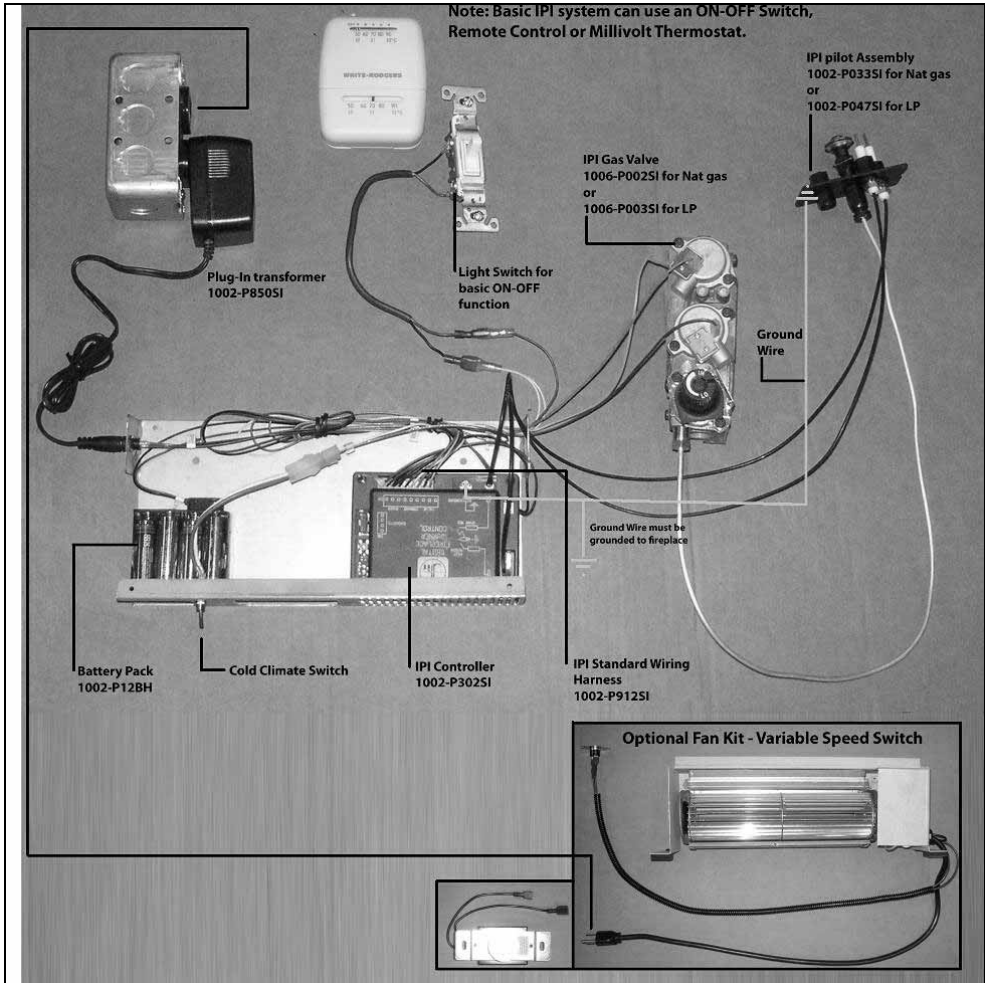

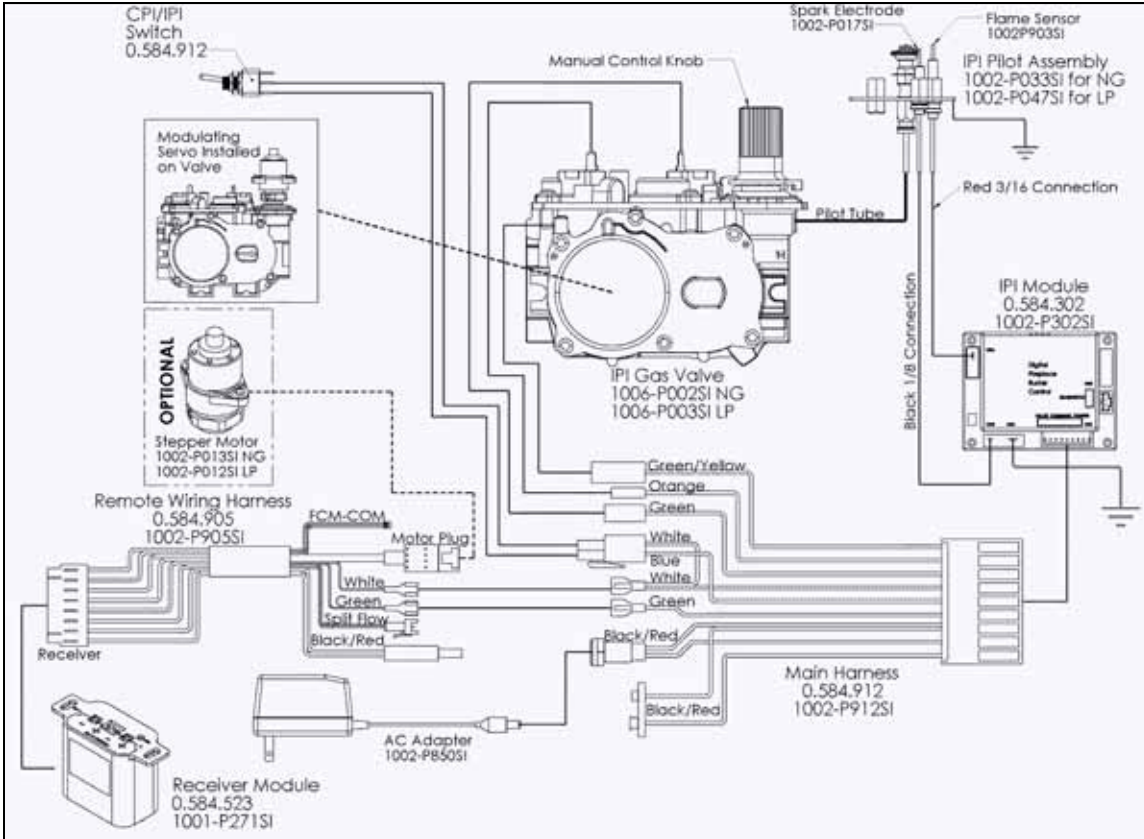

Configuration #2: Remote ON/OFF and manual HI/LO capabilities. OPTIONAL: For units with remote HI/LO capabilities, a modulating servo is required to be installed on the valve. The connectors to this servo must be connected to the Remote Harness as shown in the figure above.

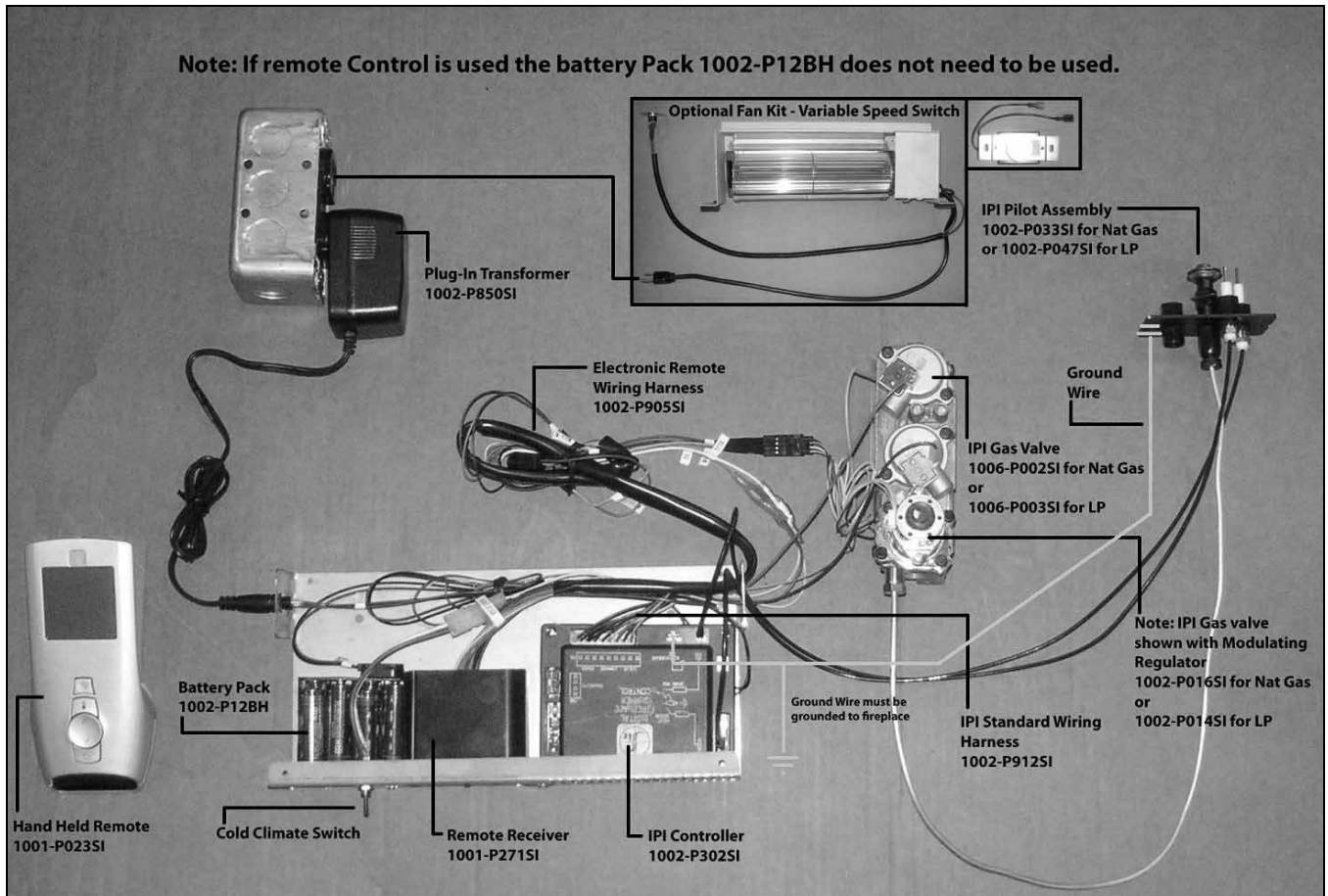

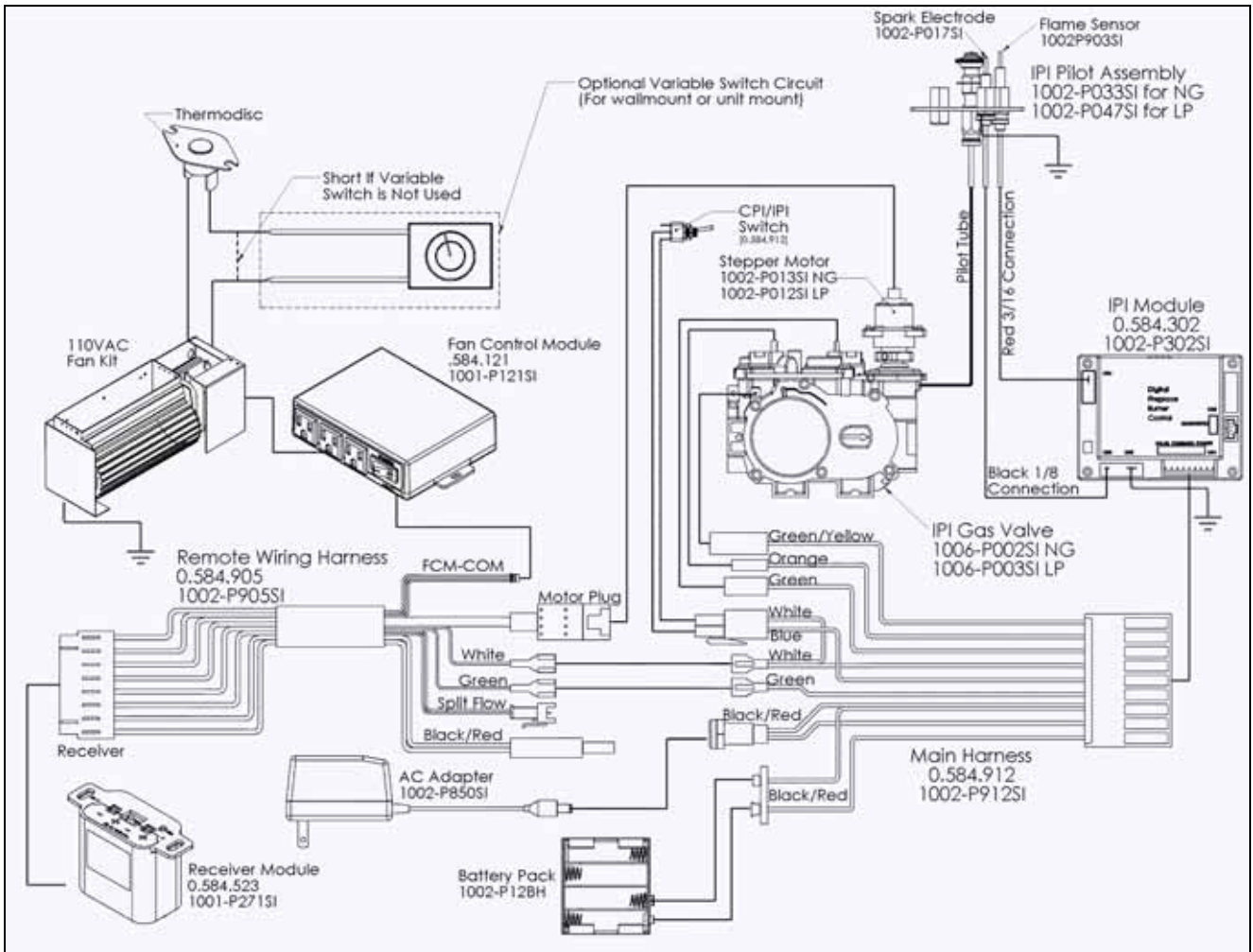

Configuration #3: Remote ON/OFF, variable HI/LO, and fan capabilities. Refer to the Fan Installation/Removal Guide section for fan installation.

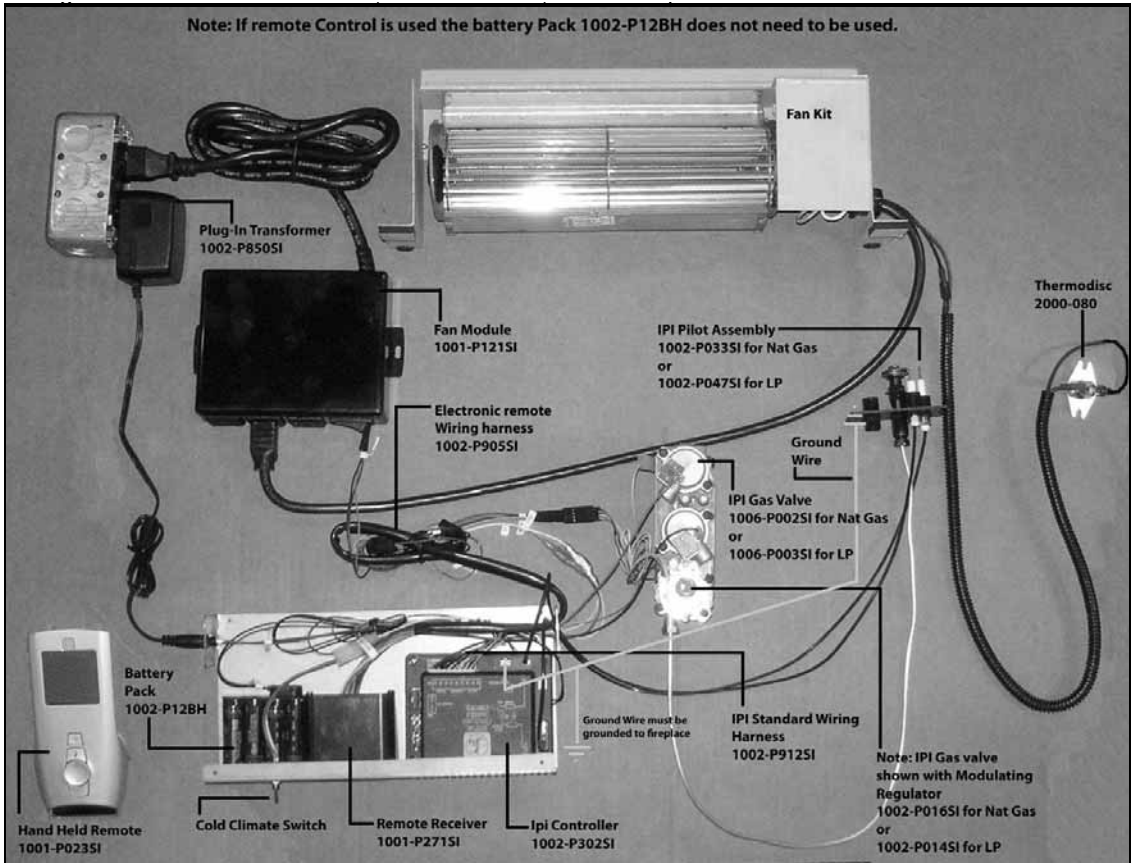

IPI Lighting Instructions



WARNING

1. If you do not follow these instructions exactly, a fire or explosion may result causing property damage, personal injury or loss of life.
2. Always light the pilot whether for the first time or if the gas supply has ran out with the glass door opened or removed.

FOR YOUR SAFETY READ BEFORE LIGHTING



- A. This fireplace is equipped with an ignition device which automatically lights the pilot. Do not try to light by hand.
- B. Before operating smell all around the fireplace area for gas and next to the floor because some gas is heavier than air and will settle on the floor.
- C. Do not use this fireplace if any part has been under water. Immediately call a qualified service technician to inspect the fireplace and replace any part of the control system and any gas control which has been under water



WHAT TO DO IF YOU SMELL GAS

- | | |
|--|--|
| <ol style="list-style-type: none">1. Turn off all gas to the fireplace.2. Open windows.3. Do not try to light any appliance.4. Do not touch any electric switch; do not use any phone in your building. | <ol style="list-style-type: none">5. Immediately call your gas supplier from a neighbor's phone. Follow the gas supplier's instructions.6. If you cannot reach your gas supplier, call the fire department. |
|--|--|

LIGHTING INSTRUCTIONS

1. STOP! Read the above safety information on this label.
2. Remove batteries from Receiver and/or Battery Backup Pack.
3. Turn off all electric power to the fireplace.
4. This fireplace is equipped with an ignition device which automatically lights the pilot. Do not try to light the pilot by hand.
5. Open the glass door.
6. Turn manual shutoff valve clockwise  to OFF position (located behind the access panel).
7. Wait five [5] minutes to clear out any gas. If you smell gas including near the floor, STOP! Follow "B" in the above safety information on this label. If you don't smell gas go to the next step.
8. Turn manual shutoff valve counter-clockwise  to ON position.
9. Close the glass door.
10. Turn on all electric power to the fireplace, and re-install batteries into the Transmitter/Receiver and/or Battery Backup Pack.
11. Turn ON the switch that operates the Main Burner. If using a Remote Control refer to Remote Control Operation Manual for activation.

TO TURN OFF GAS

1. Turn OFF all electric power to the fireplace if service is to be performed, including removing batteries from the Remote Transmitter/Receiver and/or Battery Backup Pack.
2. Access door inside the firebox must be removed to access the manual shutoff valve.
3. If alternate shut-off valve was installed it can be shutoff instead of going through the fireplace to access the fireplace shut off valve.

Trouble Shooting The Gas Control System



WARNING: BEFORE DOING ANY GAS CONTROL SERVICE WORK, REMOVE THE GLASS FRONT.

NOTE: Before troubleshooting the gas control system, be sure external gas shut off is in the “On” position.

Problem	Possible Causes	Corrective Action
Spark igniter will not light.	Defective or misaligned electrode at pilot.	Check for spark at electrode and pilot: if no spark and electrode wire is properly connected, replace igniter.
	Defective igniter (push-button)	Using a match, light pilot. If pilot lights, turn off pilot and push the red button again. If pilot will not light - check gap at electrode and pilot should be 1/8” to 1/4” to have a strong spark.
Pilot will not stay lit after carefully following lighting instructions.	Defective thermocouple (flame switch where applicable)	Check pilot flame. Must impinge on generator and thermocouple. Clean and/or adjust pilot for maximum flame impingement on generator and thermocouple. Replace thermocouple if pilot will not hold. (Hand tight 1/8 turn on replacement)
	Defective valve magnet.	Replace valve, if pilot won't hold after the thermocouple is replaced.
Pilot burning, no gas to burner, Valve knob “ON”, Wall Switch “ON”	Wall switch or wires defective	Check wall switch and wires for proper connections. Jumper wire across terminals at wall switch. If burner comes on, replace defective wall switch. If okay, jumper wires, across wall switch wires at valve. If burner comes on, wires are faulty or connections are bad.
	Generator may not be generating sufficient voltage.	Check generator with millivolt meter. Take reading at generator terminals of gas valve. Should read 325 millivolts minimum while holding valve knob depressed in pilot position and wall switch “off”. Replace faulty generator if reading is below specified minimum.
	Plugged burner orifice.	Check burner orifice for stoppage and remove.
	Defective automatic valve operator.	Remove wall switch wires from gas valve. Install jumper wires from top bottom terminals of gas valve. Turn valve on “ON”. If main burner does not light, replace valve.
Frequent Pilot outage problem.	Pilot flame may be too low or blowing (high) causing the pilot safety to drop out.	Clean and/or adjust pilot flame for maximum flame impingement on generator and thermocouple.
Flame lifts off burner and goes out in less than 30 seconds	Inner 4” liner has come off flue or termination, flame is starving for oxygen	Attach 4” liner to flue or termination using screws, silicone and clamps as stated in manual.
Flame lifts off burner on one side while the rest of the flame remains lit.	Improper installation of firebrick. Firebrick is likely leaning.	Be sure to position firebrick against firebox walls and be sure to use brick clips attached to the inner side of firebox.

LOGC50 Log Assembly

 **WARNING:** Failure to position the parts in accordance with these diagrams or failure to use only parts specifically approved with this appliance may result in property damage or personal injury.

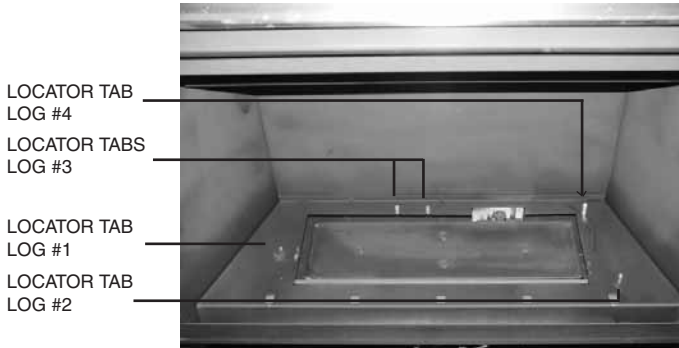
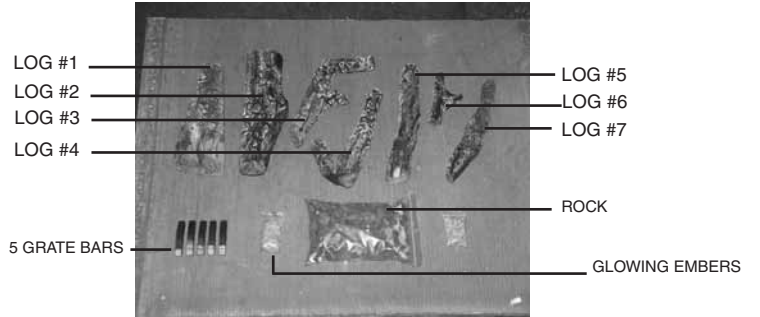

UNIT SHOWN.

STEP 1 - Units are equipped with latches. To remove glass door, unfasten latches and lift door off bottom door retainer.

STEP 2 - Remove logs from carton and inspect each log.

STEP 3 - Place the five grate bars (packaged with unit) into the grate bar slots.



STEP 4 - Locate left side Log #1 locator tab. Place Log #1 onto locator tab by aligning placement hole on the underside of Log #1 with tab.



STEP 5 - Locate right side Log #2 locator tab. Place Log #2 onto locator tab by aligning placement hole on the underside of Log #2 with tab.



STEP 6 - Locate the log locator tabs for Log #3. The notched area of Log #3 is to be positioned up against the two tabs and rests onto Log #1 (as illustrated).



STEP 7 - Locate Log #4 locator tab in the back right hand side of firebox. Butt Log #4 up to locator tab. Position short Y branch onto ledge (rear section) of Log #2. **NOTE :** Ensure at this time that logs are not sitting directly on top of open gas ports.

Log Assembly (continued)



STEP 8 - Break glowing ember insulation into 1/4" pieces. Place embers onto front burner but ensure you do not cover air slot that is located between front burner and false bottom.



STEP 9 - On Log #5, you will find a location slot that will align with the middle grate bar. Slide into place and rest Log #5 onto Log #2's flat area.



STEP 10 - Position Log #6 up against the 2nd grate from the right. Log #6 will rest onto Log #2 (Do not position over main burner ports).



STEP 11 - Lean Log #7 against the 2nd grate from the left and notch on Log #5 (Do not position over burner ports).



STEP 12 - Place rock onto the false bottom only. NOTE: Do not cover air slot that is between grate and false bottom.



STEP 13 - Sprinkle vermiculite over rocks to complete the log assembly.

Vent Termination

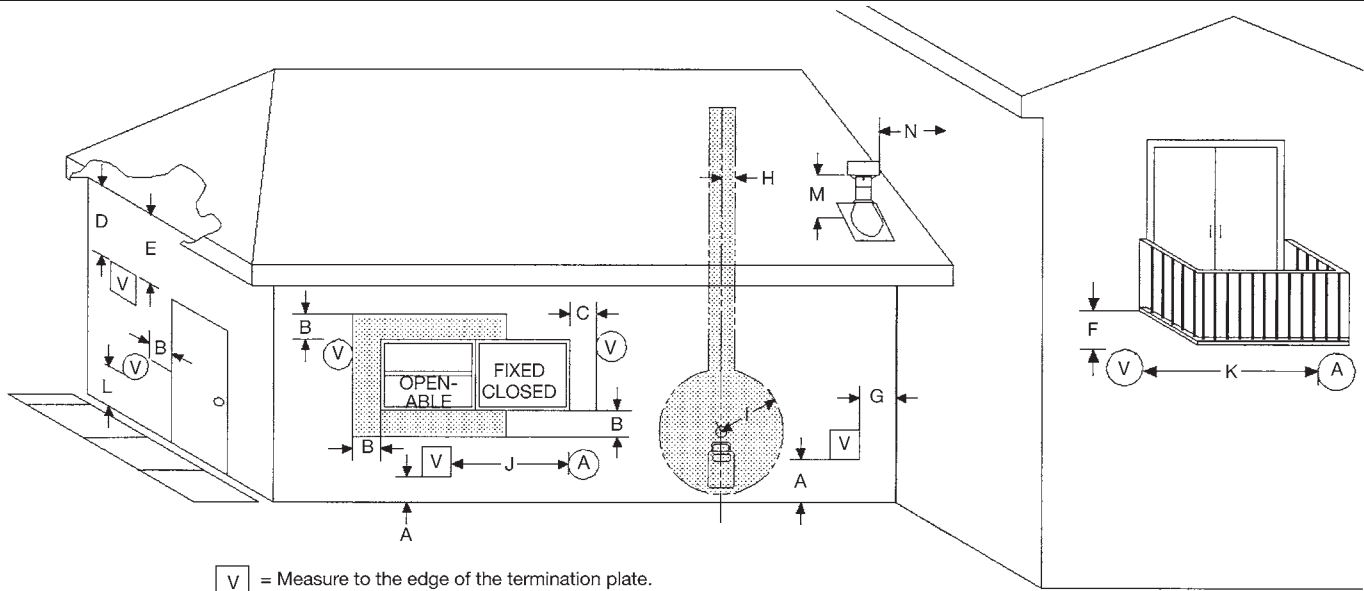

□ V = Measure to the edge of the termination plate.

○ V = Measure to the edge of the round termination.

□ Vent Terminal

○ Air Supply

■ Area Where Terminal Not Permitted.

A - Clearance above grade, veranda, porch, deck, or balcony 12 inches (30cm) minimum.¹⁻²

B - Clearance to window or door that may be opened. 12 inches (30cm) minimum for appliances 100 000 Btuh (30 kW) and lower, in Canada. 9 inches₂ (23cm) for appliances 50 000 Btuh and lower, in USA.

C - Clearance to permanently closed window minimum 12 inches (30cm) recommended to prevent condensation on window, in Canada. 9 inches₂ (23cm) for appliances 50 000 Btuh and lower, in USA.

D - Vertical clearance to ventilated soffit located above the termination within a horizontal distance of 2 feet (60cm) from the center line of the termination. 18 inches (46cm) minimum.⁵

E - Clearance to unventilated soffit 12 inches (30cm) minimum.

F - Clearance under veranda, porch, deck or balcony 12 inches₁ (30cm) minimum.⁴ US₅

G - Clearance from a perpendicular inside wall or outer corner to the edge of the vent terminal plate is 3" (minimum).

H - Clearance to each side of center line extended above meter/regulator assembly 3 feet (91cm) within a height 15 feet (4.5m) above the meter/regulator assembly.

I - Clearance to service regulator vent outlet 3 feet (91cm) minimum.¹ US₅

J - Clearance to non-mechanical air supply inlet to building or the combustion air inlet to any other appliance: In Canada, 6 inches (15cm) for appliances ≤10,000 Btuh (3kW), 12 inches₁ (30cm) minimum for appliances >10,000 Btuh (3kW) and ≤100,000 Btuh (30kW), 36 inches (91cm) for appliances >100,000 Btuh (30kW). In the USA, 6 inches₂ (15cm) for appliances ≤10,000 Btuh (3kW), 9 inches (23cm) for appliances >10,000 Btuh (3kW) and ≤50,000 Btuh (15kW), 12 inches (30cm) for appliances >50,000 Btuh (15kW).

K - Clearance to a mechanical air supply inlet 6 feet (1.8m) minimum.¹ in Canada. In USA, 3 feet (91cm) above if within 10 feet₂ (3m) horizontally.

L - Clearance above paved sidewalk or a paved driveway located on public property 7 feet (2.1m) minimum.³

M - Clearance above highest point of exit on roof 18 inches (45cm).

N - Clearance to perpendicular wall 24 inches (60 cm).

(Recommended to prevent re-circulation of exhaust products. For additional requirements check local codes.)

NOTE: Clearances are to the edge of terminal plate, add 6-3/4" to clearances to arrive at center line.

NOTE: Local Codes or Regulations may require different clearances.

Termination

It is imperative that the vent termination be located observing the minimum clearances as shown. There must not be any obstruction such as bushes, garden sheds, fences, decks or utility buildings within 24" from the front of the termination plate.

Do not locate termination where excessive snow or ice build-up may occur. Be sure to check vent termination area after snow falls and clear to prevent accidental blockage of venting system. When using snow blowers, make sure snow is not directed towards vent termination area.

General Venting Information

The gas fireplace is approved to be vented either through the side wall or vertically through the roof.

This appliance is approved with Kingsman flex vent system and also approved for use with Simpson Duravent Direct Vent System (model DV-GS series), AmeriVent Direct Vent Pipe System and Selkirk Direct Temp.

Kingsman flex vent system can be used with Simpson Duravent Direct Vent termination's (model DV-GS series).

When using Simpson Duravent, AmeriVent Direct Vent pipe, or Selkirk Direct Temp a Kingsman/Duravent adapter must be used.

ONLY VENTING COMPONENTS SPECIFICALLY APPROVED AND LABELED FOR THIS FIREPLACE MAY BE USED.

Venting terminal shall not be recessed into a wall or siding. If finishing the outside wall with vinyl or wood siding it is recommended that a Siding Shield be installed, Part Number ZDVSSLR.

1 - In accordance with the current *CSA B149.1, Natural Gas and Propane Code*.

2 - In accordance with the current *ANSI Z223.1/NFPA 54, National Fuel Gas Code*.

3 - A vent shall not terminate directly above a sidewalk or paved driveway that is located between two single family dwellings and serves both dwellings.

4 - Permitted only if veranda, porch, deck, or balcony is fully open on a minimum of two sides beneath the floor.

5 - Clearance in accordance with local installation codes and the requirements of the gas supplier.

General Vent Installation Information

This gas appliance is approved to be vented either through the side wall or vertically through the roof. **Only Kingsman Flex(Z-Flex)Venting Kits and components specifically approved and LABELED for this stove may be used.** This appliance is also approved for use with Simpson-Duravent Direct Vent system (Model DV-GS Series), Ameri-Vent Direct Vent Pipe System, ICC Excel Direct, Metal Fab Sure-Seal DV and Selkirk Direct Temp.

RIGID OR HARD PIPE

When using Simpson Duravent, AmeriVent pipe, ICC Excel Direct, Metal Fab Sure-Seal DV and or Selkirk Direct Temp a Duravent hardpipe adapter must be used (**part # ZDVDFDA for fireplaces and part # ZDVDKA for Stoves, Serenity and ZDV3624B**). Follow installation instructions provided by Simpson Duravent/AmeriVent/Selkirk Direct Temp, ICC Excel Direct, Metal Fab Sure-Seal DV for installation of pipe and adhere to the clearance to combustibles provided in this manual. Apply a bead of Mill Pac high temp sealant to all joints of pipes, adapters and termination, when using Kingsman Flex(Z-Flex)Venting and Simpson Duravent venting.

NOTE: Increase framing depth by one inch when using hardpipe.

Flex Pipe Venting

Kingsman Flex pipe is shipped in unexpanded length. When installing pipe expand the lengths. Pipe can be expanded to twice their lengths e.g. 4ft. to 8ft. Fully expand pipe and cut off excess.

Do not use more than 2 couplers to extend short pipes. Single sections are preferred in an installation attaching at the fireplace and termination.

Place the spring spaces provided approximately every two feet to stabilize 4" flex in the center of 7" flex. When forming bends place spring in bend or before and after. (See Fig. 1). Horizontal runs require support metal straps every 2 feet. In off set installation support straps should be used to stabilize pipe.

Expand 4" and 7" flex pipe to the point that the 7" protrudes approximately 2 to 3 inches past outer wall and the 4" flex protrudes approximately 2 to 3 inches past the 7" flex. See Fig. 1. Attach the 4" pipe to the termination first and secure with sealant and screws then attach the 7" flex to the termination with caulking and screws. Termination may then be moved back to the outer wall and attached to home screwing into the framing. Silicone around termination to waterproof. If siding shield is going to be used attach this using same attaching hole as the top of termination after termination has been caulked for water proofing.

Use Hi Temp Sealant

Apply a bead of mill pac high temp sealant to all joints and use four screws to secure each pipe at fireplace, termination and any joint if joining any sections of pipe.

FRAMING DIMENSION

Combustible Wall

Cut a 11" hole through exterior wall and frame as shown below.

Non combustible Wall

Cut or drill 8" or 204mm diameter hole.

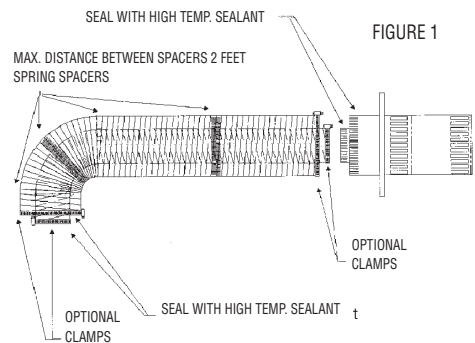

NOTE: It is critical to the proper and safe operation of this fireplace that on all connections the inner liner and the outer casing are both caulked with liberal amounts of sealant. Do not use any kind of tape or silicone other than that recommended in this manual, Mill Pac Sealant



WARNING: DO NOT mix parts from different systems unless stated in the manual.

Installation Of Side Wall Venting

- To determine the minimum distance from the bottom of fireplace to centre of vent see page 7 for the ZDV3318 and page 10 for the ZDV3622. Cut a hole through the wall allowing for a 11" x 11" (inside diameter) in combustible walls for wall thimble or an 8" diameter hole in a non-combustible wall (See Figure 2).
- For the clearance to combustibles above a 90 degree bend see page 15.
- Select the approximate vent length, precise measurements are not needed as your flex pipe can be expanded to twice its shipped length for ease of installation.
- To install wall thimble centre over 11" x 11" (inch) framing from both sides of wall and secure. Route flex vent pipe through wall thimble (See Figure 1).
- Before joining pipes, apply a bead of high temperature sealant (Mill Pac) to end of pipe. First attach the four inch (4") flue pipe to the vent termination with sealant, and secure with the four screws provided. At this time make sure the spacer springs are attached to the (4") flex pipe as required. Then attach the seven inch (7") pipe by the same method.
- Mount vent termination and seal to wall using caulking around the wall thimble to weather proof. After installing the vent termination, double check to make sure the pipe extends properly through wall thimble and into vent termination.
- Before joining pipes to fireplace flue, apply a bead of high temperature sealant (Mill Pac) to end of pipe. First attach the four inch (4") flue pipe to fireplace with sealant, and secure with the four screws provided. At this time verify that the spacer springs are attached properly to the (4") flex pipe as required. Then attach the seven inch (7") pipe by the same method.
- Support horizontal pipes every two (2) feet (61 cm) with metal strap bands. Re-check fireplace to make sure it is levelled and properly positioned and secured.
- Support vertical pipes to maintain a minimum of 1" or greater clearance to combustibles with metal strapping bands.
- If finishing the outside wall with vinyl or wood siding it is recommended that a Siding Shield be installed, Part Number ZDVSSLR.

Note: Vent Termination must not be recessed into wall or siding.

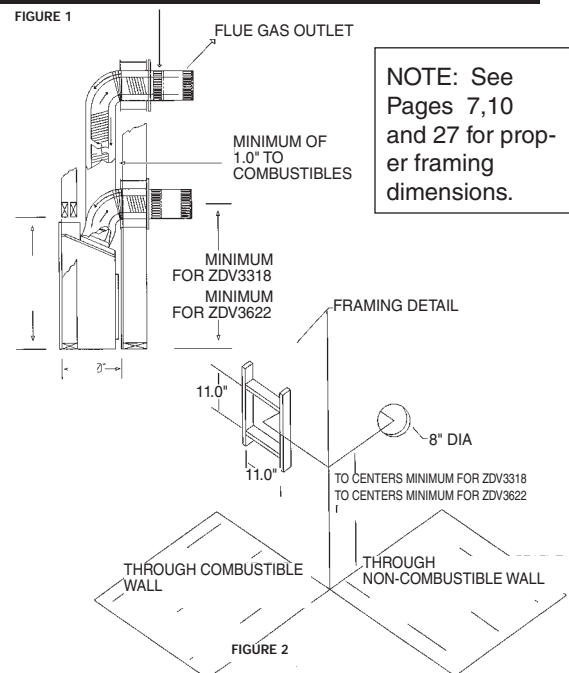

NOTE: See Pages 7,10 and 27 for proper framing dimensions.

Venting Routes And Components

Since it is very important that the vent system maintain its balance between the combustion air intake and the flue gas exhaust, certain limitations as to vent configurations apply and must be strictly adhered to.

The table showing the relationship between vertical and horizontal side wall venting will help to determine the various vent lengths.

The maximum horizontal run with the 90 degree bend at the fireplace flue outlet is 4 ft/122cm (Figure #1). The maximum horizontal run is 20 ft/6.1 m when the vertical run is 7 ft/2.1m (Figure #2). Note: 1/4" vertical rise is required for every 12" of horizontal run.

The maximum number of 45 degree bends per side wall installation is two (2) in the horizontal run and then you must reduce the length of the horizontal by 18 inches for each 45 degree bend.

The maximum vertical run is 40 ft/12.2 meters.

Special Note: For each 45 degree bend installed in the horizontal run, the length of the horizontal run must be reduced by 18" (45cm). This does not apply if the 45 degree bends are installed on the vertical part of the vent system.

Example: If according to the table, the length of the horizontal run is 10 feet, and two 45 degree bends are required, the horizontal run length must be reduced to 7 feet.

2 additional 90° bends or equals are allowed. The horizontal run must be reduced by 36" per each 90° bend, or 18" per each 45° bend.

Important: Always locate the fireplace in such a way that a minimum of offsets and/or horizontal runs are required. 1/4" vertical rise is required for every 12" horizontal run.

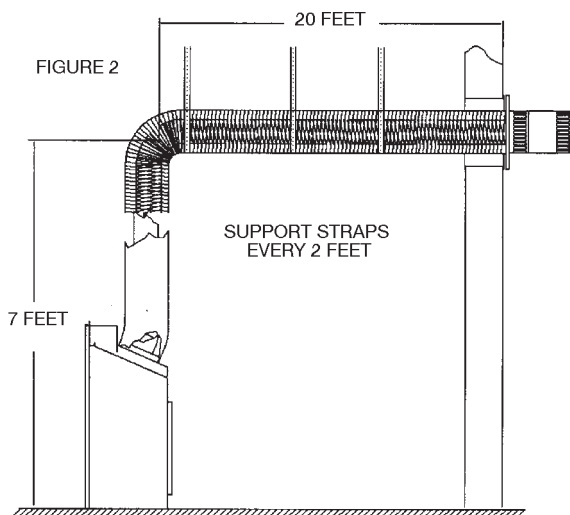
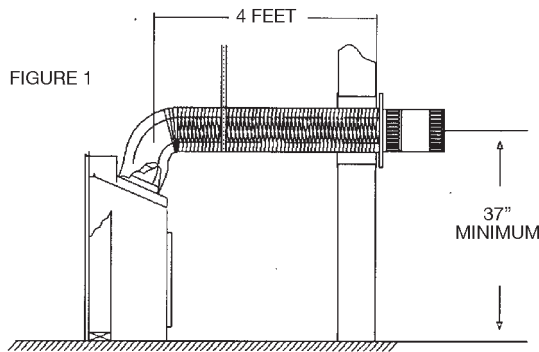

How To Use The Horizontal Vent Table

1. Determine the height of the system and the number of bends required.
2. Having determined the vertical distance determine the maximum horizontal section allowed.
3. Vent table has been established for 90° horizontal/vertical runs. With use of flex pipe distance not having 90° bends will not fall into vent table standards. See Fig. B.

Horizontal Venting Table From Bottom of Fireplace

for venting to a maximum of 40 ft. (12.2 meters)

Total Vertical		Max Total Horizontal	
Feet	Meters	Feet	Meters
4	1.2	5	1.5
5	1.5	8	1.2
6	1.8	12	3.7
7	2.1	20	6.1
8	2.4	20	6.1
9	2.7	20	6.1
10	3.0	20	6.1
11	3.4	20	6.1
12	3.7	20	6.1
13	4.0	20	6.1
14	4.3	20	6.1
15	4.6	20	6.1
16	4.9	20	6.1
17	5.2	20	6.1
18	5.5	20	6.1
19	5.8	20	6.1
20	6.1	20	6.1
25	7.5	15	4.6
30	9	10	3.0
40	12.2	0	0

Example A:

If the vertical dimension from the floor of the fireplace is 6ft, the horizontal run to the wall flange of the vent termination must not exceed 12ft.

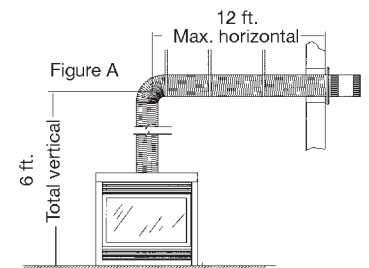

NOTE: The final location of the fireplace must be such that the horizontal vent dimensions fall within those stated on the graph. The Maximum Vertical vent run is 40ft. (12.2 meters).

Important: Minimum clearance between vent pipes and combustible materials is 1 inch (25mm).

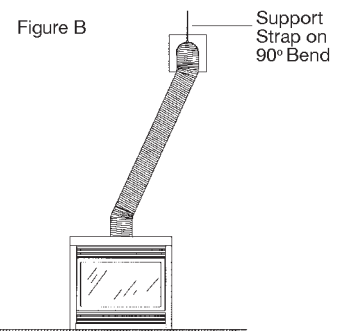

It is recommended for **Propane Horizontal Installations** that the venting should be a minimum of one foot vertical off the flue before the elbow on any horizontal runs of one foot or greater. This allows for cleaner combustion and greatly reduces carboning and cleaning of glass. (Does not apply to Back Flue Models).

Venting Straight Up Through Roof

1. An Attic Insulation Shield must be installed where the vent passes from a lower living space into an attic space where the chimney is not enclosed. It is designed to keep insulation materials away from the chimney. See Fig. 1.
2. When installing the Attic Insulation Shield where the chimney passes from a living space to an attic space, install the shield from below and nail in place using 1" spiral nails.
3. A fire stop must be installed on the bottom side of the joists when passing through a ceiling or floor. If an attic insulation shield is to be used, a fire stop is not required.

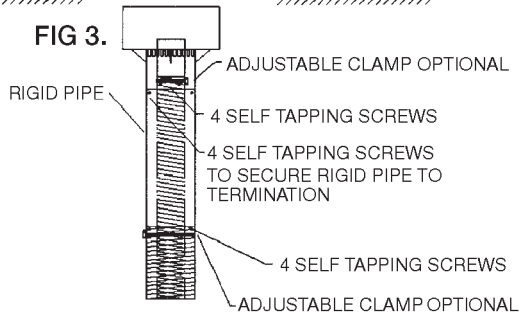
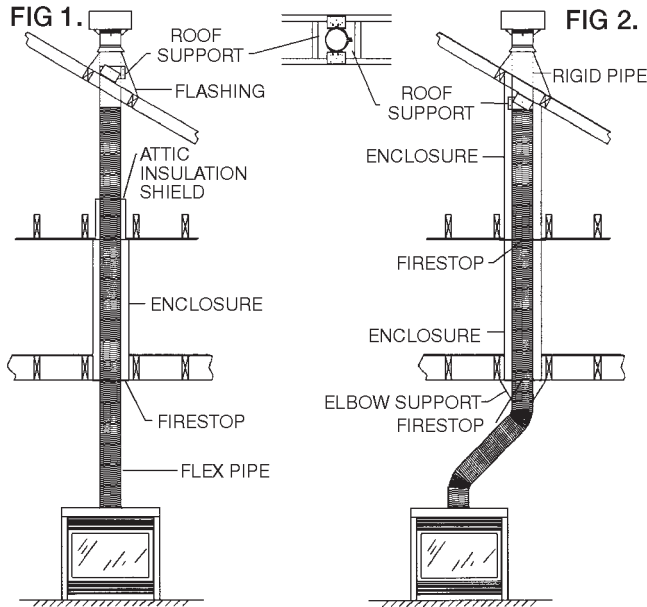

Using Flex Bends

4. Avoid cutting joists by offsetting the flex pipe. See Fig. 2.
5. When using 45° bends a bend support is required directly above the highest bend.
6. When installing a bend in a joist area a minimum of 2 1/2" clearance to combustible to the top of bend must be maintained, sides and bottom of pipe, a 1" clearance to combustibles must be maintained. If running horizontal through an area a 1 1/2" minimum clearance to the top of the horizontal pipe must be maintained.
7. Maximum vertical height of system should not exceed 40 feet.
8. Use roof support and 7" rigid pipe at roof level. Flex not permitted within roof support.
9. When penetrating the roof a rigid 7" galvanized pipe must be used. Attach the 7" flex to the 7" rigid with high temperature sealant, secure with four screws assuring the flex and rigid pipe are secured. 4" flex pipe must be secured the same way with 4 screws but must penetrate the 4" flex and 4" section of termination. Attach 7" rigid pipe to 7" termination with sealant and screw with 4 sheet metal screws. (See Fig. 3).
10. Vertical termination clearance is 18" (inches) above the roof, measured from highest point of exit on the roof line.
11. Support vertical pipes to maintain minimum of one inch or greater clearances to combustibles.

Roof Flashing

Ensure that you have the proper roof flashing by checking your roof pitch using a level and two rulers, or by using a roof pitch card. See figure below.

Slide a Roof Flashing suitable to your roof slope over the vent. Place the edge of the flashing plate that will be on the higher part of the roof slope under the shingles. Both the sides and the lower edge lay on top of the shingles.

NOTE: At the top edge of the flashing plate, lift the shingles and nail the plate to the roof deck, then cement the shingles to the plate with a suitable waterproof mastic.

Ensure that the chimney is plumb. Square up the flashing plate and nail in place to the roof deck. Use 12 nails with neoprene washers or cover the heads with a suitable waterproof mastic.

Wrap the storm collar around the vent above the flashing. Secure the ends together loosely with nut and bolt supplied. Slide the collar down the vent until it comes in contact with the flashing. Tighten the bolt and seal the Storm Collar to the vent with a suitable waterproof non-combustible mastic.

The flashing and storm collar should be painted to match the roof shingles. This will extend its life and improve the appearance. Clean, prime and paint with suitable painting products.

Vertical Venting in Cold Climates

In cold climate conditions where temperatures go below -10 degrees Celsius or 14 degrees Fahrenheit, we recommend that the chase be insulated and where the vent pipe enters into the attic space that the pipe be wrapped with an insulated mylar sleeve. This will increase the temperature of the vent and help the appliance to vent properly in cold weather conditions.

It is also important in vertical vented direct vent appliances that the appliance be operated daily during the winter months as this will help stop the Termination from freezing up. We recommend using a thermostat set at room temperature to allow the unit to cycle.

For IPI models it may be necessary to set the appliance to Standing Pilot mode to maintain heat in the cavity. The purpose of this procedure is to prevent cold air from penetrating the chimney and then onto the living space. Therefore, when the internal temperature is slightly elevated the fireplace is able to freely exhaust its combustion and hence making it easier to startup.

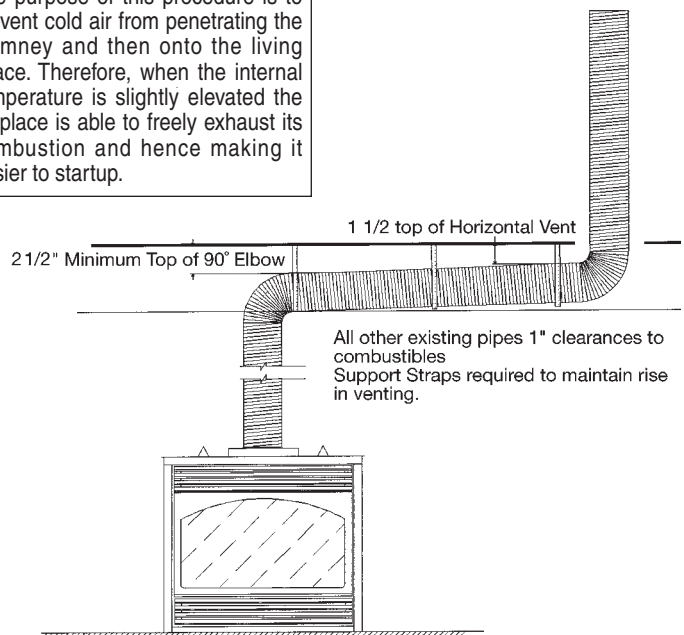
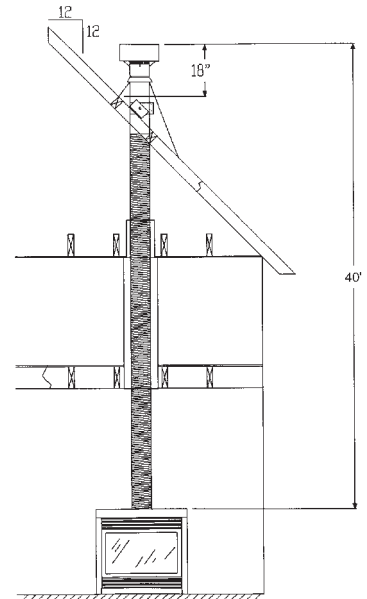

Vertical Venting over 15 Feet

The Air Intake plate must be adjusted down to the lowest position when venting over 15 ft. vertical.

15' OR OVER VERTICAL VENTING AIR INTAKE ADJUSTMENT PLATE

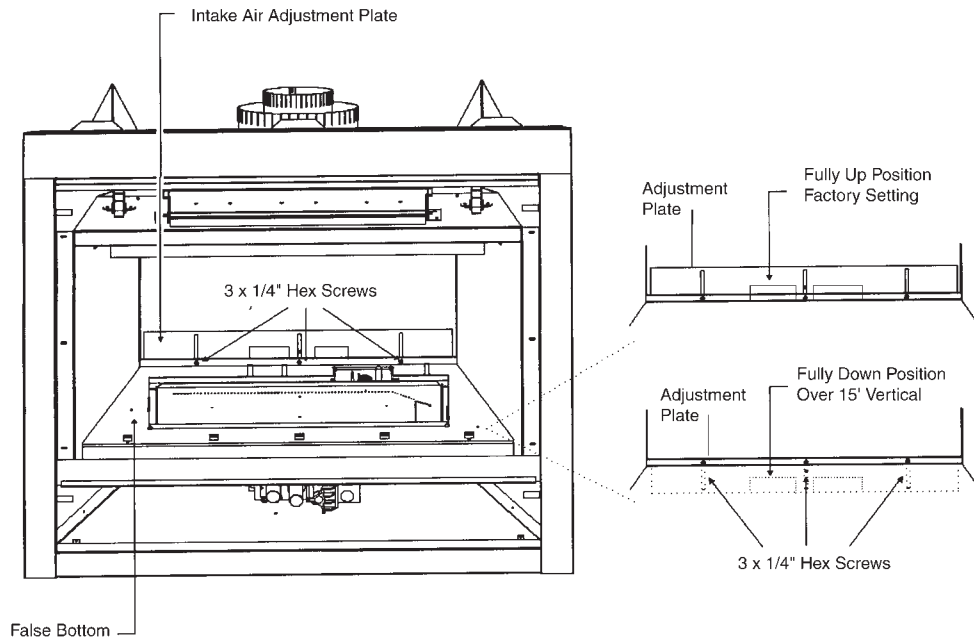

NOTE: Unit comes preset for short horizontal or vertical venting under a 15 feet run.

Follow these instructions when venting exceeds 15 foot run.

1. Locate the 3 x 1/4" hex screws and using a nut driver loosen the screws 1 turn.
2. Lower the Air Adjustment Plate as shown in the diagrams. (Fully Down Position).
3. Tighten the 3 x 1/4" hex screws.

ZDV3318 Parts List

Fireplace Part Numbers

ZDV3318N (Millivolt) Fireplace Heater Rated NG, Tempered Glass,
ZDV3318NE (IPI) 19,000 BTU AT 75% efficient. Approved for
bedroom and mobile home.

ZDV3318LP (Millivolt) Fireplace Heater Rated LP, Ceramic Glass,
ZDV3318LPE (IPI) 18,000 BTU AT 75% efficient. Approved for
bedroom and mobile home.

FIREPLACE REQUIREMENTS

Grills or CVCK (clean view circulating kit)(Required for each unit)

Z33CVCK CVCK(clean view circulating kit) no grill required
Z6GBA Grill Kit - Classic Builder Antique Brass
Z6GBC Grill Kit - Classic Builder Chrome
Z6GBP Grill Kit - Classic Builder Polish Brass
VI30GBL Grill Kit - Black
Z33PBL Panel Grill Kit - Black

LOG SETS (Required for each unit)

LOGC50 Log Set Campfire

FIREPLACE ACCESSORIES OPTIONS

Fireplace Surrounds - Trims

Z6SAB Surround - Antique Brass
Z6SCR Surround - Chrome
Z6SPB Surround - Polish Brass
Z33SLAB Surround Slim Line - Antique Brass
Z33SLCR Surround Slim Line - Chrome
Z33SLPB Surround Slim Line - Polish Brass
Z33SLBL Surround Slim Line - Gun Metal Black

Designer Doors for 33" Fireplaces - Operative

Z33DDA1BL Designer Door Arch - Series 1 - Black
Z33DDTA1A Trim - Antique for Designer Arch - Series 1
Z33DDTA1C Trim - Chrome for Designer Arch - Series 1
Z33DDTA1P Trim - Polish Brass for Designer Arch - Series 1
Z33DDS1BL Designer Door Straight - Series 1 - Black
Z33DDS2BL Designer Door Straight - Series 2 - Black
Z33DDS3BL Designer Door Straight - Series 3 - Black
Z33DDTS1A Trim - Antique for Designer Straight - Series 1
Z33DDTS1C Trim - Chrome for Designer Straight - Series 1
Z33DDTS1P Trim - Polish for Designer Straight - Series 1

Child Safety Screens

Z33CSS Child Safety Screen - 33" DV Fireplaces

Overlays

Z33ADDX Arch Door Frame - Deluxe Black (352)
Z33ADTH Arch Door Frame - Top Half Black (353T)
Z33ADDA Arch Door Frame - Double Arch Black (354)
Z33ADDD Arch Door Frame - Double Door Arch Black (355)
Z6ADBL Arch Door Frame Black

Fan Kit/ Blower

Z33FK Fan Kit w/Variable Speed Wall Mount Control
(Temperature Sensing)
6000-P930 Blower Motor QLN657/1800(Z33FK MOTOR)

Refractory Liners

Z3318PRL Porcelain Reflective Liner
Z3318ML Metal Liner Traditional

Door Glass

6000-151 Tempered Glass - ZDV3318
6000-150 Ceramic Glass - ZDV3318

Replacement Burner Assembly

3318-BNGSI Burner Assembly - Natural Gas c/w Valve System
(ZDV3318N)
3318-BLPSI Burner Assembly - Liquid Propane c/w Valve
System (ZDV3318LP)

Conversion Kit (Sit Valve Only)

3318-CKLP Propane Conversion Kit (Millivolt)
3318-CKNG Natural Gas Conversion Kit (Millivolt)
3318-CKLPI Propane Conversion Kit (IPI)
3318-CKNGI Natural Gas Conversion Kit (IPI)

MARQUIS WALL SURROUND COLLECTION

Fireplace Wall Mount Finishing Surrounds for Z33CVCK Unit

MQ33SWFBL Surround Flat Black
(Coverage 35 5/16" H x 45 13/16" W)
MQ33SWFPW Surround Flat Pewter
(Coverage 35 5/16" H x 45 13/16" W)

Marquis Wall Surround Accents (Four Pieces)

MQ33SWAKSB Wall Surround Accents - Keystone Black
MQ33SWAKSC Wall Surround Accents - Keystone Chrome
MQ33SWABBC Wall Surround Accents -
Band Black x 4, Chrome x 2
MQ33SWACB Wall Surround Accents - Corner Black

ZDV3622 Parts List

Fireplace Part Numbers

ZDV3622N (Millivolt) ZDV3622 NE (IPI)	Fireplace Heater Rated NG, Tempered Glass, 21,000 BTU AT 75% efficient. Approved for bedroom and mobile home.
ZDV3622LP (Millivolt) ZDV3622LPE (IPI)	Fireplace Heater Rated LP, Ceramic Glass, 21,000 BTU AT 75% efficient. Approved for bedroom and mobile home.

FIREPLACE REQUIREMENTS

Grills or CVCK (clean view circulating kit)(Required for each unit)

Z36CVCK	CVCK(clean view circulating kit) no grill required
Z36GBA	Grill Kit - Classic Builder Antique Brass
Z36GBC	Grill Kit - Classic Builder Chrome
Z36GBP	Grill Kit - Classic Builder Polish Brass
Z1GBL	Grill Kit - Black
Z36PBL	Decorate Black Panel Grill Kit

LOG SET (Required for each unit)

LOGC50	Log Set Campfire
MQROCK1	Rock Set
MQRSP5	Rock Platform, Support

FIREPLACE ACCESSORIES OPTIONS

Fireplace Surrounds - Trims

Z36SAB	Surround - Antique Brass
Z36SCR	Surround - Chrome
Z36SPB	Surround - Polish Brass
Z36SLAB	Surround Slim Line - Antique Brass
Z36SLCR	Surround Slim Line - Chrome
Z36SLPB	Surround Slim Line - Polish Brass
Z36SLBL	Surround Slim Line - Gun Metal Black

Designer Doors for 36" Fireplaces - Operative

Z36DDA1BL	Designer Door Arch - Series 1 - Black
Z36DDTA1A	Trim - Antique for Designer Arch - Series 1
Z36DDTA1C	Trim - Chrome for Designer Arch - Series 1
Z36DDTA1P	Trim - Polish Brass for Designer Arch - Series 1
Z36DDS1BL	Designer Door Straight - Series 1 - Black
Z36DDS2BL	Designer Door Straight - Series 2 - Black
Z36DDS3BL	Designer Door Straight - Series 3 - Black
Z36DDTS1A	Trim - Antique for Designer Straight - Series 1
Z36DDTS1C	Trim - Chrome for Designer Straight - Series 1
Z36DDTS1P	Trim - Polish for Designer Straight - Series 1

Child Safety Screens

Z36CSS	Child Safety Screen - 33" DV Fireplaces
--------	---

Overlays

Z36ADDX	Arch Door Frame - Deluxe Black (352)
Z36ADTH	Arch Door Frame - Top Half Black (353T)
Z36ADDA	Arch Door Frame - Double Arch Black (354)
Z36ADDD	Arch Door Frame - Double Door Arch Black (355)
Z1ADBL	Arch Door Frame Black

Fan Kit/ Blower

Z36FK	Fan Kit w/Variable Speed Wall Mount Control (Temperature Sensing)
6000-081	Blower Motor QLN657/1800(Z36FK MOTOR)

Refractory Liners

Z3622PRL	Porcelain Reflective Liner
Z3622ML	Metal Liner Traditional

Door Glass

3600-311	Tempered Glass - ZDV3622
1000-305	Ceramic Glass - for all ZDV3600

Replacement Burner Assembly

3622-BNGSI	Burner Assembly - Natural Gas c/w Valve System (ZDV3622N)
3622-BLPSI	Burner Assembly - Liquid Propane c/w Valve System (ZDV3622LP)

Conversion Kit (Sit Valve Only)

3622-CKLP	Propane Conversion Kit (Millivolt)
3622-CKNG	Natural Gas Conversion Kit (Millivolt)
3622-CKLPI	Propane Conversion Kit (IPI)
3622-CKNGI	Natural Gas Conversion Kit (IPI)

MARQUIS WALL SURROUND COLLECTION

Fireplace Wall Mount Finishing Surrounds for Z36CVCK Unit

MQ36SWFBL	Surround Flat Black (Coverage 37 5/32" H x 50 5/16" W)
MQ36SWFPW	Surround Flat Pewter (Coverage 37 5/32" H x 50 5/16" W)

Marquis Wall Surround Accents (Four Pieces)

MQ36SWAKSB	Wall Surround Accents - Keystone Black
MQ36SWAKSC	Wall Surround Accents - Keystone Chrome
MQ36SWABBC	Wall Surround Accents - Band Black x 4, Chrome x 2
MQ36SWACB	Wall Surround Accents - Corner Black

Kingsman Parts ZDV3318/3622

Catalog Number	Description
Valve System Parts - New Top convertible SIT (Millivolt)	
1000-P136WR	Generator/Thermopile
1001-P069SI	Electrode Sparker 915.069 TC SIT
1001-P216SI	Thermocouple 290.216 TC SIT
1001-P165SI	Orifice Pilot NG 977.165 TC SIT
1001-P167SI	Orifice Pilot LP 977.167 TC SIT
1001-P280SI	Tubing 24"
1001-P633SI	Valve Nova LP Hi/Lo 0820651
1001-P634SI	Valve Nova NG Hi/Lo 0820652
1001-P713SI	Pilot Burner LP 199.713 TC SIT
1001-P714SI	Pilot Burner NG 199.714 TC SIT
Valve System Parts - IPI System	
Electronic Ignition/Remote Control IPI	
EGTRC	Remote Control IPI (Thermostat)
EGTMRCN	Remote Control IPI (Thermostat/Modulating - NG)
EGTMRCP	Remote Control IPI (Thermostat/Modulating - LP)
EGTFRCN	Remote Control IPI (Thermostat/Modulating/Fan - NG)
EGTFRCP	Remote Control IPI (Thermostat/Modulating/Fan - LP)
Electronic Ignition Replacement Parts IPI	
1002-P001si	Valve IPI (NG; ON/OFF)
1002-P002si	Valve IPI (LP; ON/OFF)
1006-P002si	Valve IPI (NG; Hi/Lo)
1006-P603si	Valve IPI (LP; Hi/Lo)
1002-P047si	Pilot Assembly (LP)
1002-P033si	Pilot Assembly (NG)
1002-P089si	Spark Electrode (Long)
1002-P113si	Electrode Flame Sensor (Long)
1002-P302si	IPI Ignition Board
1002-P850si	AC Wall Adapter
1002-P12BH	Battery Pack
1002-P912si	Wiring Harness
1002-P166si	Orifice Pilot (NG #62)
1002-P168si	Orifice Pilot (LP #35)
1002-P013si	Stepper Motor (NG)
1002-P012si	Stepper Motor (LP)
1002-P016is	Hi/Lo Regulator (NG)
1002-P014si	Hi/Lo Regulator (LP)
Miscellaneous Parts	
1000-150GE	#Silicone GE Red IS806 #736
1000-150MP	#Hi-Temp Millpac Sealant 840099
1000-214	#Piezo-Igniter 1244-17 MARK 21
1000-215	#Pal Nut (18MMX1.5MM)BLK (1364.03)
1000-218	#Switch Ivory (1451/001)
1000-227	#Cover Ivory (86001/001)
1000-255	#Orifice Brass - (State Size)
6000-130	#Explosion felt Gasket
2000-080	#Thermodisc 2450 (For Blower)
1000-306	Thermalcord - Adhesive Back for Door Frame
1000-085	#Control Variable Speed KBWC-13BV

Kingsman Fireplace Venting

Catalog Description	Number
Accessories	
Z1MT	Thermostat Millivolt Wall Mount
Z80PT	Thermostat Programmable Digital Millivolt Wall Mount (1F80-40)
ZIRC	Remote Control Millivolt (On/Off with LED)(Model1)
ZART	Remote Control Thermostat Millivolt (Model K)
RMCBN	Remote Control - Basic - Natural Gas (On/Off,Hi/Lo Flame Adjustment)
RMCBP	Remote Control - Basic - Liquid Propane (On/Off, Hi/Lo Flame Adjustment)
DCHS	Remote Control Heatshield
VLBIT4	Log Bits - Large Four Piece Kit
VLBIT6	Log Bits - Small Six Piece Kit
ZDVHSK	Horizontal Vent Starter Kit - 3 FT Length Horizontal Vent Termination, Wall Thimble, 36" Flex Pipe, Mill Pac.
ZDVHSK5	Horizontal Vent Starter Kit - 5 FT Length Horizontal Vent Termination, Wall Thimble, 60" Flex Pipe, Mill Pac.
FDVVT40	Vertical Vent Termination converts from 15'-40' to 15' and under
FDVHT	Horizontal Vent Termination
FDVHSQ	Horizontal Square Termination
ZDVST	Horizontal Snorkel Termination (34" Tall, 24" Center to Center)
FDVHSCU	Safety Cage for Horizontal Termination
ZDVAIS	Attic Insulation Shield
ZDVVOS	Offset Support
ZDVFS	Firestop Spacer
ZDVRS	Roof Support
ZDVWT	Wall Thimble (Horizontal Venting)
ZDVSSLR	Siding Shield - Large Return
ZDV48GP	Galvanized Pipe 7" Dia. x 48" (Vertical Installations)
ZDVAAF	Flashing 7" c/w Storm Collar (1/12 to 7/12)
ZDVAF2	Flashing 7" c/w Storm Collar (8/12 to 12/12)
ZDVAF3	Flashing 7" c/w Storm Collar Flat
ZDV7SC	Storm Collar 7"
ZDVFK5	Flex Kit (4" & 7" Dia.) x 2.5' (Unexpanded) 5' Expanded
ZDVFK8	Flex Kit (4" & 7" Dia.) x 4' (Unexpanded) 8' Expanded
ZDVFK20	Flex Kit (4" & 7" Dia.) x 10' (Unexpanded) 20' Expanded *Kits are complete with spring stand-offs, silicone.
ZDV4FC	Flex Connector 4" Diameter
ZDV7FC	Flex Connector 7" Diameter
ZDV4SS	Spring 4" Standoff Spacer
ZDVDFFA	Dura-Vent Fireplace Adapter (for ZDV33/36/42/47, ZDV6000, MDV30/38 & HB models)
ZDVHKSQ	Horizontal Square Termination Vent Starter Kit -3 FT Length Horizontal Vent Termination, Wall Thimble, Wall Thimble, 36" Flex Pipe, Mill Pac
ZDVHKSQ5	Horizontal Square Termination Vent Starter Kit -5 FT Length Horizontal Vent Termination, Wall Thimble, Wall Thimble, 60" Flex Pipe, Mill Pac
FDVHSQ	Horizontal Square Vent Termination



LIMITED LIFETIME WARRANTY

This Limited Lifetime Warranty applies only while the unit remains at the site of the original installation and only if the unit is installed inside the continental United States, Alaska, Hawaii, and Canada. The warranty applies only if the unit is installed and operated in accordance with the printed instructions and in compliance with applicable installation and building codes and good trade practices.

BASIC ONE YEAR WARRANTY

During the first year after installation, we will provide a replacement for any component part of your unit found to be defective in materials or workmanship, including labour costs. Repair work requires prior approval by Kingsman, labour costs are based on a predetermined rate schedule and any repair work must be done through an authorized Kingsman dealer.

LIMITED LIFETIME WARRANTY

The heat exchanger, combustion chamber and burner of every Kingsman product excluding the Outdoor Firepit are warranted against materials or workmanship during the period the product is owned by the original owner. The part to be replaced must be returned to our distributor in exchange for the replacement part. Any labor, material, freight and/or handling charges associated with any repair or replacement pursuant to this Limited Lifetime Warranty will not be covered by this warranty.

GENERAL TERMS

In lieu of providing a replacement part, we may, at our option, provide the distributor's component purchase price from us or a credit equal to the distributors component purchase price from us toward the purchase of any new unit which we distribute. If a credit is given in lieu of a replacement part, the rating plate from the unit being replaced must be submitted on a warranty claim, and the unit being replaced must be made available to our distributor for disposition.

In establishing the date of installation for any purpose, including determination of the starting date for the term of this Limited Lifetime Warranty, reasonable proof of the original installation date must be presented*, otherwise the effective date will be based upon the date of manufacture plus thirty (30) days.

We will not be responsible for and you, the user, will pay for: (a) damages caused by accident, abuse, negligence, misuse, riot, fire, flood, or Acts of God (b) damages caused by operating the unit where there is a corrosive atmosphere containing chlorine, fluorine, or any other damaging chemicals (other than in a normal residential environment) (c) damages caused by any unauthorized alteration or repair of the unit affecting its stability or performance (d) damages caused by improper matching or application of the unit or the unit's components (e) damages caused by failing to provide proper maintenance and service to the unit (f) any expenses incurred for erecting, disconnecting or dismantling the unit (g) parts or supplies used in connection with service or maintenance (h) damage repairs, inoperation or inefficiency resulting from faulty installation or application (i) electricity or fuel costs or any increase in electricity or fuel cost whatsoever including additional or unusual use of supplemental electric heat.

We shall not be liable for any incidental, consequential, or special damages or expenses in connection with any use or failure of this unit. We have not made and do not make any representation or warranty of fitness for a particular use or purpose, and there is no implied condition of fitness for a particular use or purpose. We make no express warranties except as stated in this Limited Lifetime Warranty. No one is authorized to change this Limited Lifetime Warranty or to create for us any other obligation or liability in connections with this unit. Any implied warranties shall last for one year after the original installation. Some states and provinces do not allow the exclusion or limitation of incidental or consequential damages or do not allow limitations on how long an implied warranty or condition lasts, so the above limitations or exclusions may not apply to you. The provisions of this limited warranty are in additions to and not a modification of or subtraction from any statutory warranties and other rights and remedies provided by law.

Save this certificate. It gives you specific legal rights, and you may also have other rights which may vary from state to state and province to province.

In the event your unit needs servicing, contact your dealer or contractor who installed or serviced your unit. When requesting service, please have the model and serial number from each unit readily available. If your dealer needs assistance, the distributor is available for support and we, in turn support the distributor's efforts.

Fill in the installation date and model and serial numbers of the unit in the space provided below and retain this limited warranty for your files.

Model No. _____ Serial No. _____ Date installed _____

Dealer or Contractor Name: _____

*To receive advantage of your warranty, you must retain the original records that can establish the installation date of your unit.